

# LPC1768 MICRO-BLOX

## Easy and Comprehensive CORTEX-M3 Evaluation

The Future LPC1768 Micro-Blox is a flexible evaluation platform for rapid microcontroller assessment and prototyping. It features the LPC1768 CORTEX-M3 32-bit microcontroller from NXP Semiconductor, allowing quick and easy evaluation of the full range of capabilities and features of the low power LPC1700 family of NXP microcontrollers.

The LPC1768 microcontroller features a CORTEX-M3 core capable of operating up to 100MHz; 512KB on-chip Flash; 64 KB on-chip SRAM; 10/100 Ethernet MAC; USB 2.0 Full speed controller (OTG/Host /Device); two CAN 2.0B controllers; three SSP/SPI controllers; three I2C interface (one supporting Fast mode plus – 1Mbit/s data rate); I2S interface for digital audio; 8 channel 12-bit ADC; 10-bit Digital-to-Analog Converter.

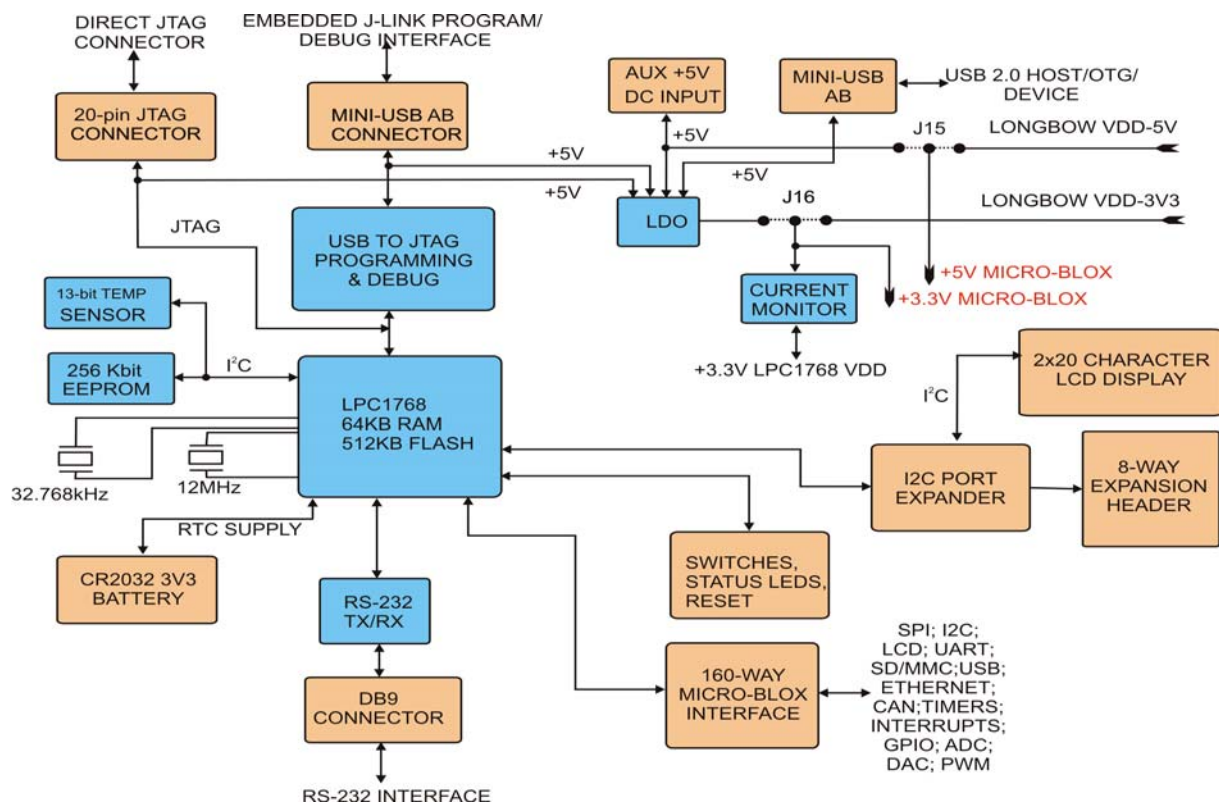

Block Diagram of FUTURE LPC1768 Micro-Blox

### LPC1768 Micro-Blox Features

- LPC1768 Cortex-M3 microcontroller in LQFP100 package
- LDO regulator to provide local +3.3V supply from USB, JTAG or AUX +5V supply
- On-board LPC1768 VDD supply current monitor IC or direct ammeter reading
- Embedded J-Link interface using dedicated USB port for easy programming and debugging
- 20-pin standard JTAG header for direct connection to multi-vendor tools
- Embedded Trace Module (ETM) connector pad-out
- USB 2.0 Host/OTG/Device configuration (with EEP006 Longbow EVB)
- 256Kbit I2C EEPROM
- 13-bit I2C Temperature Sensor with thermostat control output
- On-board +3V3 Lithium CR2032 or External battery for RTC powering facility
- Main Crystal Oscillator 12.000MHz and 32.768KHz RTC/watchdog
- 8-bit I2C Port Expander/output LED drive
- On-board 2 x 20 LCD Character display with backlight
- 4 User Input switches/output LED drive
- 160 pin Micro-Blox interface supporting 3 x UART channels; USB 2.0 Host/OTG/Device; 2 x SSP/SPI; 3 x I2C; I2S digital audio; 6 x PWM; 8 x Match/Capture/Compare inputs; 4 interrupts; RTC alarm; 8 x ADC inputs; 1 DAC output; Ethernet MII interface; 10 x GPIO

## Tools Provided

The LPC1768 Micro-Blox device evaluation is supported by an evaluation copy of EWARM IDE (program size limited) and a range of software application programs /peripheral drivers provided by IAR Systems on the supplied Future Electronics reference CDROM. Additionally, as it becomes available, up-dated support material will be available on the Future Board Club web-site, [www.my-boardclub.com](http://www.my-boardclub.com) This is supplementary to other Public Domain software resources freely available from, for example, NXP Semiconductor web-site and embedded microcontroller support Forums.

## Additional Functionality offered by Longbow base-board

For added capability enabling greater system evaluation, the LPC1768 Micro-Blox may be used with the Longbow base-board. The combined Longbow and Micro-Blox package allows a wider range of peripheral functionality supported on a dual-board solution supporting the following additional features:

(Note: Not all these features will be available with the LPC1768 Micro-Blox)

- 160 pin Micro-Blox daughter board interface
- 160 pin Future-Blox Rev2.3 board-board expansion interface
- RS-232, IRDA, RS485, CAN2.0B interface
- Current Monitoring via ammeter or current monitor IC
- USB2.0 Host and OTG
- 20x2 header for Bluetooth and WLAN modules
- 20x2 header supporting ZIGBEE wireless modules
- SD Memory Card interface
- 16x2 LCD Character display
- Piezo sounder for variable tone audio feedback
- Ethernet port supporting 10/100Base-T/TX with precision time stamping for IEEE1588 applications
- Audio Codec and Class D audio amp (UDA1344/SA58670BS-G from NXP Semiconductor)
- SERDES support for LCD (DS90UR124IVS from National Semiconductor)
- LCD Touchscreen controller (LM8300 from National Semiconductor)
- Direct connection to selected NEC TFT LCD's

Part Number	Size
NL2432HC22-41K	3.5" QVGA with integrated touch-screen
NL8060BC21-03	8.4" SVGA
NL6448BC-63D/C	10.1" VGA
NL8060BC31-41D	12.1"SVGA
NL10276BC24-13	12.1" XGA



Making the Difference