

### Atmel OLED1 Xplained Pro

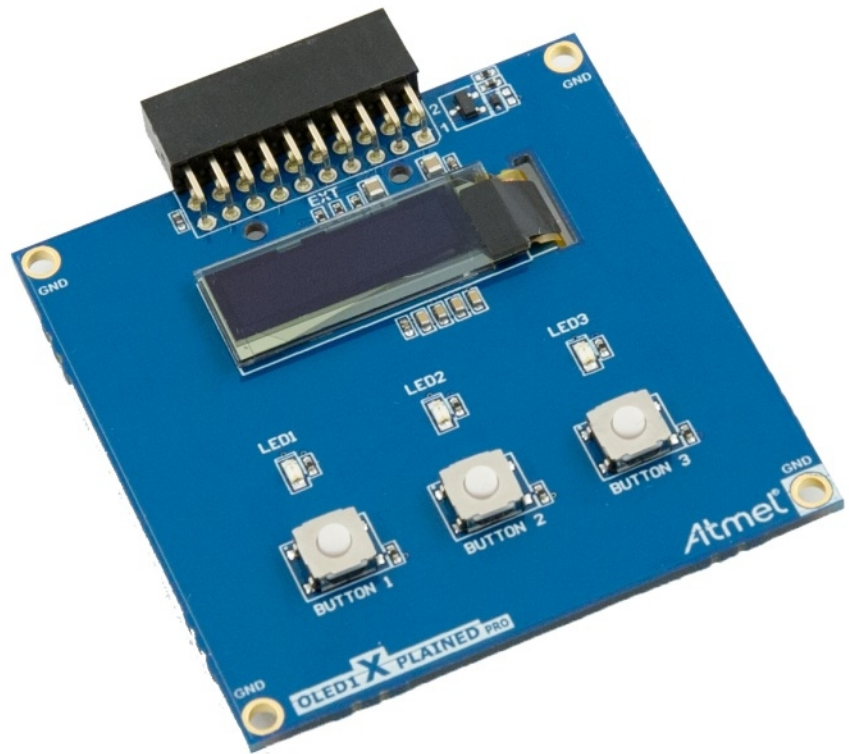

## Preface

Atmel® OLED1 Xplained Pro is an extension board to the Atmel Xplained Pro evaluation platform. The board enables the user to experiment with user interface applications with buttons, LEDs and a display.

## Table of Contents

---

Preface .....	1
<b>1. Introduction .....</b>	<b>3</b>
1.1. Features .....	3
1.2. Kit overview .....	3
<b>2. Getting started .....</b>	<b>4</b>
2.1. 3 Steps to start exploring the Atmel Xplained Pro platform .....	4
2.2. Connecting OLED1 Xplained Pro to the Xplained Pro MCU board. ....	4
2.3. Design documentation and related links .....	4
<b>3. Xplained Pro .....</b>	<b>5</b>
3.1. Hardware identification system .....	5
3.2. Standard headers and connectors .....	5
3.2.1. Xplained Pro Standard Extension Header .....	5
<b>4. Hardware user guide .....</b>	<b>7</b>
4.1. Headers and connectors .....	7
4.1.1. OLED1 Xplained Pro extension header .....	7
4.2. Peripherals .....	7
4.2.1. LEDs .....	7
4.2.2. Push buttons .....	7
4.2.3. OLED display .....	8
<b>5. Hardware revision history and known issues .....</b>	<b>9</b>
5.1. Identifying product ID and revision .....	9
5.2. Revision 3 .....	9
<b>6. Document revision history .....</b>	<b>10</b>
<b>7. Evaluation board/kit important notice .....</b>	<b>11</b>

# 1. Introduction

## 1.1 Features

- UG-2832HSWEG04 monochrome OLED display
  - 128 x 32 Pixels
  - Controlled by 4-wire SPI interface, up to 100MHz
- Three LEDs
- Three Mechanical push buttons
- Xplained Pro hardware identification system

## 1.2 Kit overview

OLED1 Xplained Pro is a basic extension board for the Xplained Pro platform with three LEDs, three push buttons and an OLED display. The OLED display is controlled via a SPI interface up to 100MHz. OLED1 Xplained Pro connects to any Xplained Pro standard extension header on any Xplained Pro MCU board.

Figure 1-1. OLED1 Xplained Pro top overview.

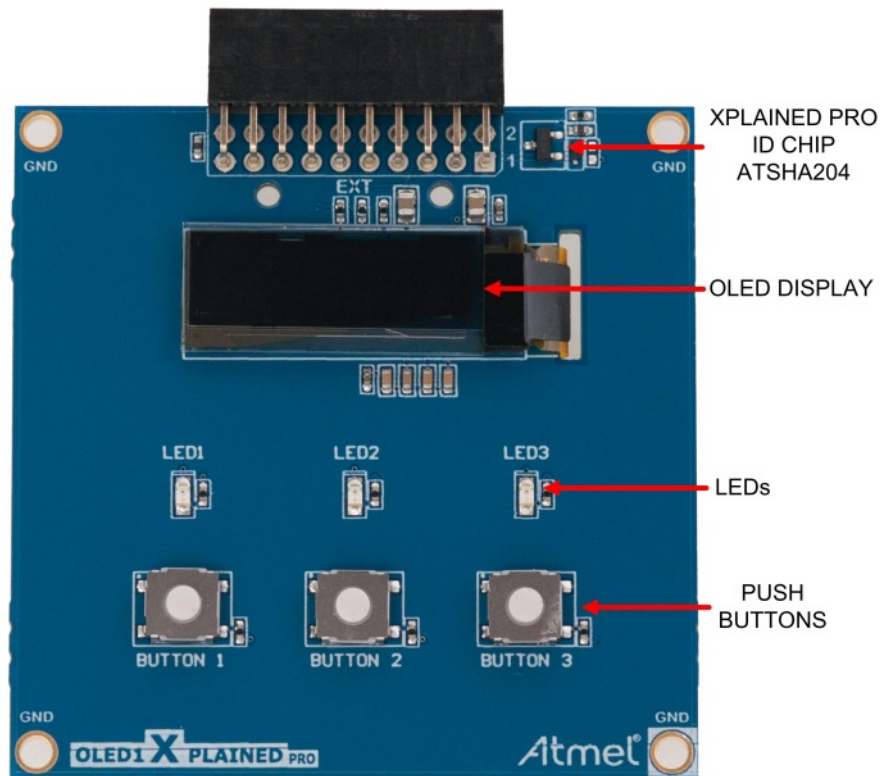

## 2. Getting started

### 2.1 3 Steps to start exploring the Atmel Xplained Pro platform

1. Download and install [Atmel Studio](#).
2. Launch Atmel Studio.
3. Connect OLED1 Xplained Pro to an Xplained Pro MCU board and connect a USB cable to DEBUG USB port on the Xplained Pro MCU board.

### 2.2 Connecting OLED1 Xplained Pro to the Xplained Pro MCU board.

Atmel OLED1 Xplained Pro has been designed to be connected to the Xplained Pro header marked EXT3. However it is compatible with all Xplained Pro EXT headers. Please refer to the pin-out of your Xplained Pro evaluation kit to find out which Xplained Pro EXT headers that can be used.

Once the Xplained Pro MCU board is powered the green power LED will be lit and Atmel Studio will auto detect which Xplained Pro MCU- and extension board(s) that is connected. You will be presented with relevant information like datasheets and kit documentation. You also have the option to launch Atmel Software Framework (ASF) example applications. The target device is programmed and debugged by the on-board Embedded Debugger. No external programmer or debugger tool is needed.

### 2.3 Design documentation and related links

The following list contains links to the most relevant documents and software for OLED1 Xplained Pro.

1. [Xplained Pro products](#)<sup>1</sup> - Atmel Xplained Pro is a series of small-sized and easy-to-use evaluation kits for 8- and 32-bit Atmel microcontrollers. It consists of a series of low cost MCU boards for evaluation and demonstration of features and capabilities of different MCU families.
2. [OLED1 Xplained Pro User Guide](#)<sup>2</sup> - PDF version of this User Guide.
3. [OLED1 Xplained Pro Design Documentation](#)<sup>3</sup> - Package containing schematics, BOM, assembly drawings, 3D plots, layer plots etc.
4. [Atmel Studio](#)<sup>4</sup> - Free Atmel IDE for development of C/C++ and assembler code for Atmel microcontrollers.

<sup>1</sup> <http://www.atmel.com/XplainedPro>

<sup>2</sup> [http://www.atmel.com/Images/Atmel-42077-OLED1-Xplained-Pro\\_User-Guide.pdf](http://www.atmel.com/Images/Atmel-42077-OLED1-Xplained-Pro_User-Guide.pdf)

<sup>3</sup> [http://www.atmel.com/Images/Atmel-42077-OLED1-Xplained-Pro\\_User-Guide.zip](http://www.atmel.com/Images/Atmel-42077-OLED1-Xplained-Pro_User-Guide.zip)

<sup>4</sup> <http://www.atmel.com/atmelstudio>

## 3. Xplained Pro

Xplained Pro is an evaluation platform that provides the full Atmel microcontroller experience. The platform consists of a series of Microcontroller (MCU) boards and extension boards that are integrated with Atmel Studio, have Atmel Software Framework (ASF) drivers and demo code, support data streaming and more. Xplained Pro MCU boards support a wide range of Xplained Pro extension boards that are connected through a set of standardized headers and connectors. Each extension board has an identification (ID) chip to uniquely identify which boards are mounted on a Xplained Pro MCU board. This information is used to present relevant user guides, application notes, datasheets and example code through Atmel Studio. Available Xplained Pro MCU and extension boards can be purchased in the [Atmel Web Store](http://store.atmel.com/)<sup>1</sup>.

### 3.1 Hardware identification system

All Xplained Pro compatible extension boards have an Atmel ATSHA204 CryptoAuthentication™ chip mounted. This chip contains information that identifies the extension with its name and some extra data. When an Xplained Pro extension board is connected to an Xplained Pro MCU board the information is read and sent to Atmel Studio. The Atmel Kits extension, installed with Atmel Studio, will give relevant information, code examples and links to relevant documents. [Table 3-1, “Xplained Pro ID Chip Content” on page 5](#) shows the data fields stored in the ID chip with example content.

**Table 3-1. Xplained Pro ID Chip Content**

Data Field	Data Type	Example Content
Manufacturer	ASCII string	Atmel'\0'
Product Name	ASCII string	Segment LCD1 Xplained Pro'\0'
Product Revision	ASCII string	02'\0'
Product Serial Number	ASCII string	1774020200000010'\0'
Minimum Voltage [mV]	uint16_t	3000
Maximum Voltage [mV]	uint16_t	3600
Maximum Current [mA]	uint16_t	30

### 3.2 Standard headers and connectors

#### 3.2.1 Xplained Pro Standard Extension Header

All Xplained Pro kits have one or more dual row, 20 pin, 100mil extension headers. Xplained Pro MCU boards have male headers while Xplained Pro extensions have their female counterparts. Note that all pins are not always connected. However, all the connected pins follow the defined pin-out described in [Table 3-2, “Xplained Pro Extension Header” on page 5](#). The extension headers can be used to connect a wide variety of Xplained Pro extensions to Xplained Pro MCU boards and to access the pins of the target MCU on Xplained Pro MCU board directly.

**Table 3-2. Xplained Pro Extension Header**

Pin number	Name	Description
1	ID	Communication line to the ID chip on extension board.
2	GND	Ground.
3	ADC(+)	Analog to digital converter , alternatively positive part of differential ADC.
4	ADC(-)	Analog to digital converter , alternatively negative part of differential ADC.
5	GPIO1	General purpose I/O.
6	GPIO2	General purpose I/O.
7	PWM(+)	Pulse width modulation , alternatively positive part of differential PWM.
8	PWM(-)	Pulse width modulation , alternatively positive part of differential PWM.

<sup>1</sup> <http://store.atmel.com/>

Pin number	Name	Description
9	IRQ/GPIO	Interrupt request line and/or general purpose I/O.
10	SPI_SS_B/GPIO	Slave select for SPI and/or general purpose I/O.
11	TWI_SDA	Data line for two wire interface. Always implemented, bus type.
12	TWI_SCL	Clock line for two wire interface. Always implemented, bus type.
13	USART_RX	Receiver line of Universal Synchronous and Asynchronous serial Receiver and Transmitter.
14	USART_TX	Transmitter line of Universal Synchronous and Asynchronous serial Receiver and Transmitter.
15	SPI_SS_A	Slave select for SPI. Should be unique if possible.
16	SPI_MOSI	Master out slave in line of Serial peripheral interface. Always implemented, bus type.
17	SPI_MISO	Master in slave out line of Serial peripheral interface. Always implemented, bus type.
18	SPI_SCK	Clock for Serial peripheral interface. Always implemented, bus type.
19	GND	Ground.
20	VCC	Power for extension board.

## 4. Hardware user guide

### 4.1 Headers and connectors

#### 4.1.1 OLED1 Xplained Pro extension header

OLED1 Xplained Pro implements one [Xplained Pro Standard Extension Header on page 5](#) marked with EXT in silkscreen. This header makes it possible to connect the board to any Xplained Pro MCU board. The pin-out definition for the extension header can be seen in [Table 4-1, “OLED1 Xplained Pro extension header” on page 7](#).

**Table 4-1. OLED1 Xplained Pro extension header**

Pin Number	Function	Description
1	ID	Communication line to ID chip
2	GND	Ground
3	BUTTON2	Push button 2, active low
4	BUTTON3	Push button 3, active low
5	DATA_CMD_SEL	Data / command select for OLED display. High = data, low = command.
6	LED3	LED3, active low
7	LED1	LED1, active low
8	LED2	LED2, active low
9	BUTTON1	Push button 1, active low
10	DISPLAY_RESET	Reset line for OLED display, active low
11	NC	
12	NC	
13	NC	
14	NC	
15	DISPLAY_SS	OLED display slave select, active low
16	SPI MOSI	MOSI signal SPI connected to OLED display
17	NC	
18	SPI SCK	Clock signal for SPI connected to OLED display
19	GND	Ground
20	VCC	Target supply voltage

## 4.2 Peripherals

### 4.2.1 LEDs

There are three yellow LEDs available on OLED1 Xplained Pro. The LEDs can be activated by driving the connected I/O line low.

**Table 4-2. LED connections**

Pin on EXT connector	Silk screen marking
7	LED1
8	LED2
6	LED3

### 4.2.2 Push buttons

There are three push buttons available on OLED1 Xplained Pro. When a button is pushed the corresponding IO pin is connected to ground. There are no external pull-up resistors on OLED1 Xplained Pro, so internal pull-up resistors have to be enabled in the target microcontroller.

**Note**

Remember to enable internal pull-up resistors in the target device to get a defined electrical level on the IO lines connected to the buttons.

**Table 4-3. Push button connections**

Pin on EXT connector	Silk screen marking
9	BUTTON1
3	BUTTON2
4	BUTTON3

**4.2.3 OLED display**

OLED1 Xplained Pro features a 128 x 32 pixel white monochrome OLED display, [UG-2832HSWEG04](#)<sup>1</sup> from WiseChip Semiconductor Inc. The display has a SSD1306 display controller by Solomon Systech built in and is controlled via a 4-wire SPI interface + reset with the signals described in [Table 4-4, “OLED display connections” on page 8](#). The datasheets for the display module or the display controller is not publicly available and has to be acquired from the respective manufacturers.

**Note**

Note that the OLED display does not have a SPI MISO signal. That means that data can only be written to the display, not read.

**Table 4-4. OLED display connections**

Pin on EXT connector	Signal Name	Description
16	SPI_MOSI	SPI master out, slave in signal. Used to write data to the display
18	SPI_SCK	SPI clock signal, generated by the master.
5	DATA_CMD_SEL	Data/command select. Used to choose whether the communication is data to the display memory or a command to the LCD controller.
15	DISPLAY_SS	SPI slave select signal, must be held low during SPI communication.
10	DISPLAY_RESET	Reset signal to the OLED display, active low. Used during initialization of the display.

<sup>1</sup> [http://www.wisechip.com.tw/english/Products\\_02-04.asp](http://www.wisechip.com.tw/english/Products_02-04.asp)



## 5. Hardware revision history and known issues

### 5.1 Identifying product ID and revision

The revision and product identifier of Xplained Pro boards can be found in two ways, through Atmel Studio or by looking at the sticker on the bottom side of the PCB.

By connecting a Xplained Pro MCU board to a computer with Atmel Studio running, an information window will pop up. The first 6 digits of the serial number, which is listed under kit details, contain the product identifier and revision. Information about connected Xplained Pro extension boards will also appear in the Atmel Kits window.

The same information can be found on the sticker on the bottom side of the PCB. Most kits will print the identifier and revision in plain text as *A09-nnnn\rr* where *nnnn* is the identifier and *rr* is the revision. Boards with limited space have a sticker with only a QR-code which contains a serial number string.

The serial number string has the following format:

```
"nnnnrrssssssssss"  
n = product identifier  
r = revision  
s = serial number
```

The kit identifier for OLED1 Xplained Pro is 1769.

### 5.2 Revision 3

Revision 3 of OLED1 Xplained Pro is the initial released version.

OLED1 Xplained Pro boards with a serial number that ends with a number lower than 11148 may have a wrong revision programmed into the Xplained Pro ID chip. This will only affect the information displayed by the Atmel Kits extension in Atmel Studio. It will not affect the operation of the board.

## 6. Document revision history

Document revision	Date	Comment
42077B	09/2013	Added errata about revision 3 of the board.
42077A	25/02/2013	First release

## 7. Evaluation board/kit important notice

This evaluation board/kit is intended for use for **FURTHER ENGINEERING, DEVELOPMENT, DEMONSTRATION, OR EVALUATION PURPOSES ONLY**. It is not a finished product and may not (yet) comply with some or any technical or legal requirements that are applicable to finished products, including, without limitation, directives regarding electromagnetic compatibility, recycling (WEEE), FCC, CE or UL (except as may be otherwise noted on the board/kit). Atmel supplied this board/kit "AS IS," without any warranties, with all faults, at the buyer's and further users' sole risk. The user assumes all responsibility and liability for proper and safe handling of the goods. Further, the user indemnifies Atmel from all claims arising from the handling or use of the goods. Due to the open construction of the product, it is the user's responsibility to take any and all appropriate precautions with regard to electrostatic discharge and any other technical or legal concerns.

EXCEPT TO THE EXTENT OF THE INDEMNITY SET FORTH ABOVE, NEITHER USER NOR ATMEL SHALL BE LIABLE TO EACH OTHER FOR ANY INDIRECT, SPECIAL, INCIDENTAL, OR CONSEQUENTIAL DAMAGES.

No license is granted under any patent right or other intellectual property right of Atmel covering or relating to any machine, process, or combination in which such Atmel products or services might be or are used.



**Atmel Corporation** 1600 Technology Drive, San Jose, CA 95110 USA    **T:** (+1)(408) 441.0311    **F:** (+1)(408) 436.4200    |    [www.atmel.com](http://www.atmel.com)

© 2013 Atmel Corporation. All rights reserved. / Rev.: 42077B-MCU-10/2013

Atmel®, Atmel logo and combinations thereof, Enabling Unlimited Possibilities®, and others are registered trademarks or trademarks of Atmel Corporation or its subsidiaries. Other terms and product names may be trademarks of others.

Disclaimer: The information in this document is provided in connection with Atmel products. No license, express or implied, by estoppel or otherwise, to any intellectual property right is granted by this document or in connection with the sale of Atmel products. EXCEPT AS SET FORTH IN THE ATMEL TERMS AND CONDITIONS OF SALES LOCATED ON THE ATMEL WEBSITE, ATMEL ASSUMES NO LIABILITY WHATSOEVER AND DISCLAIMS ANY EXPRESS, IMPLIED OR STATUTORY WARRANTY RELATING TO ITS PRODUCTS INCLUDING, BUT NOT LIMITED TO, THE IMPLIED WARRANTY OF MERCHANTABILITY, FITNESS FOR A PARTICULAR PURPOSE, OR NON-INFRINGEMENT. IN NO EVENT SHALL ATMEL BE LIABLE FOR ANY DIRECT, INDIRECT, CONSEQUENTIAL, PUNITIVE, SPECIAL OR INCIDENTAL DAMAGES (INCLUDING, WITHOUT LIMITATION, DAMAGES FOR LOSS AND PROFITS, BUSINESS INTERRUPTION, OR LOSS OF INFORMATION) ARISING OUT OF THE USE OR INABILITY TO USE THIS DOCUMENT, EVEN IF ATMEL HAS BEEN ADVISED OF THE POSSIBILITY OF SUCH DAMAGES. Atmel makes no representations or warranties with respect to the accuracy or completeness of the contents of this document and reserves the right to make changes to specifications and products descriptions at any time without notice. Atmel does not make any commitment to update the information contained herein. Unless specifically provided otherwise, Atmel products are not suitable for, and shall not be used in, automotive applications. Atmel products are not intended, authorized, or warranted for use as components in applications intended to support or sustain life.