



MICROCHIP

**EVB-LAN8770-RGMII
Evaluation Board
User's Guide**

Note the following details of the code protection feature on Microchip products:

- Microchip products meet the specifications contained in their particular Microchip Data Sheet.
- Microchip believes that its family of products is secure when used in the intended manner, within operating specifications, and under normal conditions.
- Microchip values and aggressively protects its intellectual property rights. Attempts to breach the code protection features of Microchip product is strictly prohibited and may violate the Digital Millennium Copyright Act.
- Neither Microchip nor any other semiconductor manufacturer can guarantee the security of its code. Code protection does not mean that we are guaranteeing the product is "unbreakable" Code protection is constantly evolving. Microchip is committed to continuously improving the code protection features of our products.

This publication and the information herein may be used only with Microchip products, including to design, test, and integrate Microchip products with your application. Use of this information in any other manner violates these terms. Information regarding device applications is provided only for your convenience and may be superseded by updates. It is your responsibility to ensure that your application meets with your specifications. Contact your local Microchip sales office for additional support or, obtain additional support at <https://www.microchip.com/en-us/support/design-help/client-support-services>.

THIS INFORMATION IS PROVIDED BY MICROCHIP "AS IS". MICROCHIP MAKES NO REPRESENTATIONS OR WARRANTIES OF ANY KIND WHETHER EXPRESS OR IMPLIED, WRITTEN OR ORAL, STATUTORY OR OTHERWISE, RELATED TO THE INFORMATION INCLUDING BUT NOT LIMITED TO ANY IMPLIED WARRANTIES OF NON-INFRINGEMENT, MERCHANTABILITY, AND FITNESS FOR A PARTICULAR PURPOSE, OR WARRANTIES RELATED TO ITS CONDITION, QUALITY, OR PERFORMANCE.

IN NO EVENT WILL MICROCHIP BE LIABLE FOR ANY INDIRECT, SPECIAL, PUNITIVE, INCIDENTAL, OR CONSEQUENTIAL LOSS, DAMAGE, COST, OR EXPENSE OF ANY KIND WHATSOEVER RELATED TO THE INFORMATION OR ITS USE, HOWEVER CAUSED, EVEN IF MICROCHIP HAS BEEN ADVISED OF THE POSSIBILITY OR THE DAMAGES ARE FORESEEABLE. TO THE FULLEST EXTENT ALLOWED BY LAW, MICROCHIP'S TOTAL LIABILITY ON ALL CLAIMS IN ANY WAY RELATED TO THE INFORMATION OR ITS USE WILL NOT EXCEED THE AMOUNT OF FEES, IF ANY, THAT YOU HAVE PAID DIRECTLY TO MICROCHIP FOR THE INFORMATION.

Use of Microchip devices in life support and/or safety applications is entirely at the buyer's risk, and the buyer agrees to defend, indemnify and hold harmless Microchip from any and all damages, claims, suits, or expenses resulting from such use. No licenses are conveyed, implicitly or otherwise, under any Microchip intellectual property rights unless otherwise stated.

Trademarks

The Microchip name and logo, the Microchip logo, Adaptec, AVR, AVR logo, AVR Freaks, BesTime, BitCloud, CryptoMemory, CryptoRF, dsPIC, flexPWR, HELDO, IGLoo, JukeBlox, KeeLoq, Kleer, LANCheck, LinkMD, maXStylus, maXTouch, MediaLB, megaAVR, Microsemi, Microsemi logo, MOST, MOST logo, MPLAB, OptoLyzer, PIC, picoPower, PICSTART, PIC32 logo, PolarFire, Prochip Designer, QTouch, SAM-BA, SenGenuity, SpyNIC, SST, SST Logo, SuperFlash, Symmetricom, SyncServer, Tachyon, TimeSource, tinyAVR, UNI/O, Vectron, and XMEGA are registered trademarks of Microchip Technology Incorporated in the U.S.A. and other countries.

AgileSwitch, ClockWorks, The Embedded Control Solutions Company, EtherSynch, Flashtec, Hyper Speed Control, HyperLight Load, Libero, motorBench, mTouch, Powermite 3, Precision Edge, ProASIC, ProASIC Plus, ProASIC Plus logo, Quiet-Wire, SmartFusion, SyncWorld, TimeCesium, TimeHub, TimePictra, TimeProvider, and ZL are registered trademarks of Microchip Technology Incorporated in the U.S.A.

Adjacent Key Suppression, AKS, Analog-for-the-Digital Age, Any Capacitor, AnyIn, AnyOut, Augmented Switching, BlueSky, BodyCom, Clockstudio, CodeGuard, CryptoAuthentication, CryptoAutomotive, CryptoCompanion, CryptoController, dsPICDEM, dsPICDEM.net, Dynamic Average Matching, DAM, ECAN, Espresso T1S, EtherGREEN, EyeOpen, GridTime, IdealBridge, IGaT, In-Circuit Serial Programming, ICSP, INICnet, Intelligent Paralleling, IntellIMOS,

Inter-Chip Connectivity, JitterBlocker, Knob-on-Display, MarginLink, maxCrypto, maxView, memBrain, Mindi, MiWi, MPASM, MPF, MPLAB Certified logo, MPLIB, MPLINK, mSiC, MultiTRAK, NetDetach, Omniscient Code Generation, PICDEM, PICDEM.net, PICkit, PICtail, Power MOS IV, Power MOS 7, PowerSmart, PureSilicon, QMatrix, REAL ICE, Ripple Blocker, RTAX, RTG4, SAM-ICE, Serial Quad I/O, simpleMAP, SimpliPHY, SmartBuffer, SmartHLS, SMART-I.S., storClad, SQL, SuperSwitcher, SuperSwitcher II, Switchtec, SynchroPHY, Total Endurance, Trusted Time, TSHARC, Turing, USBCheck, VariSense, VectorBlox, VeriPHY, ViewSpan, WiperLock, XpressConnect, and ZENA are trademarks of Microchip Technology Incorporated in the U.S.A. and other countries.

SQTP is a service mark of Microchip Technology Incorporated in the U.S.A.

The Adaptec logo, Frequency on Demand, Silicon Storage Technology, and Symmcom are registered trademarks of Microchip Technology Inc. in other countries.

GettIC is a registered trademark of Microchip Technology Germany II GmbH & Co. KG, a subsidiary of Microchip Technology Inc., in other countries.

All other trademarks mentioned herein are property of their respective companies.
© 2023, Microchip Technology Incorporated and its subsidiaries.

All Rights Reserved.

ISBN: 978-1-6683-3048-7

For information regarding Microchip's Quality Management Systems, please visit www.microchip.com/quality.

Table of Contents

Preface	5
Introduction.....	5
Document Layout	5
Conventions Used in this Guide	6
Warranty Registration.....	7
The Microchip Web Site	7
Development Systems Customer Change Notification Service	7
Customer Support	8
Document Revision History	8
Chapter 1. Overview	
1.1 Introduction	9
1.2 Block Diagram	9
1.3 References	10
1.4 Terms and Abbreviations	10
Chapter 2. Getting Started	
2.1 Introduction	11
2.2 Default Jumper Settings	11
2.3 power Source	11
2.3.1 EDS-Powered Operation	11
2.3.2 External-Powered Operation	11
2.4 Clock	12
2.5 Reset Circuit	12
2.5.1 Power-On Reset—EDS Reset	12
2.5.2 Manual Reset	12
2.6 Using the EVB-LAN8770-RGMII	12
2.6.1 With SAMA5D3-EDS	12
2.6.2 With EVB-LAN7431-EDS	13
2.6.3 With EVB-LAN7801-EDS	13
Chapter 3. Hardware Configuration	
3.1 Hardware Configuration Options	15
3.2 PHY Port	15
3.3 Test Points	15
3.4 Connectors	16
Appendix A. Schematics	
A.1 Introduction	17
Appendix B. Bill of Materials	
B.1 Introduction	21

EVB-LAN8770-RGMII Evaluation Board User's Guide

Worldwide Sales and Service24

Preface

NOTICE TO CUSTOMERS

All documentation becomes dated, and this manual is no exception. Microchip tools and documentation are constantly evolving to meet customer needs, so some actual dialogs and/or tool descriptions may differ from those in this document. Please refer to our web site (www.microchip.com) to obtain the latest documentation available.

Documents are identified with a “DS” number. This number is located on the bottom of each page, in front of the page number. The numbering convention for the DS number is “DSXXXXA”, where “XXXX” is the document number and “A” is the revision level of the document.

For the most up-to-date information on development tools, see the MPLAB® IDE online help. Select the Help menu, and then Topics to open a list of available online help files.

INTRODUCTION

This chapter contains general information that will be useful to know before using the EVB-LAN8770-RGMII Evaluation Board User's Guide. Items discussed in this chapter include:

- [Document Layout](#)
- [Conventions Used in this Guide](#)
- [Warranty Registration](#)
- [The Microchip Web Site](#)
- [Development Systems Customer Change Notification Service](#)
- [Customer Support](#)
- [Document Revision History](#)

DOCUMENT LAYOUT

This document describes how to use the EVB-LAN8770 RGMII Evaluation Board as a development tool for the LAN8770, 100BASE-T1 Ethernet Transceiver. The manual layout is as follows:

- **Chapter 1. “Overview”** – This shows a brief description of the EVB-LAN8770-RGMII Evaluation Board.
- **Chapter 2. “Getting Started”** – This provides information about the setup and operation of the EVB-LAN8770-RGMII Evaluation Board.
- **Chapter 3. “Hardware Configuration”** - This details the hardware configuration information of the EVB-LAN8770-RGMII Evaluation Board.
- **Appendix A. “Schematics”** – This appendix shows the EVB-LAN8770-RGMII Evaluation Board schematics.
- **Appendix B. “Bill of Materials”** – This appendix includes the EVB-LAN8770-RGMII Evaluation Board Bill of Materials.

CONVENTIONS USED IN THIS GUIDE

This manual uses the following documentation conventions:

DOCUMENTATION CONVENTIONS

Description	Represents	Examples
Arial font:		
Italic characters	Referenced books	<i>MPLAB® IDE User's Guide</i>
	Emphasized text	...is the <i>only</i> compiler...
Initial caps	A window	the Output window
	A dialog	the Settings dialog
	A menu selection	select Enable Programmer
Quotes	A field name in a window or dialog	"Save project before build"
Underlined, italic text with right angle bracket	A menu path	<u><i>File>Save</i></u>
Bold characters	A dialog button	Click OK
	A tab	Click the Power tab
N'Rnnnn	A number in verilog format, where N is the total number of digits, R is the radix and n is a digit.	4'b0010, 2'hF1
Text in angle brackets < >	A key on the keyboard	Press <Enter>, <F1>
Courier New font:		
Plain Courier New	Sample source code	#define START
	Filenames	autoexec.bat
	File paths	c:\mcc18\h
	Keywords	_asm, _endasm, static
	Command-line options	-Opa+, -Opa-
	Bit values	0, 1
	Constants	0xFF, 'A'
Italic Courier New	A variable argument	<i>file.o</i> , where <i>file</i> can be any valid filename
Square brackets []	Optional arguments	mcc18 [options] <i>file</i> [options]
Curly brackets and pipe character: { }	Choice of mutually exclusive arguments; an OR selection	errorlevel {0 1}
Ellipses...	Replaces repeated text	var_name [, var_name...]
	Represents code supplied by user	void main (void) { ... }

WARRANTY REGISTRATION

Please complete the enclosed Warranty Registration Card and mail it promptly. Sending the Warranty Registration Card entitles users to receive new product updates. Interim software releases are available at the Microchip web site.

THE MICROCHIP WEB SITE

Microchip provides online support via our web site at www.microchip.com. This web site is used as a means to make files and information easily available to customers. Accessible by using your favorite Internet browser, the web site contains the following information:

- **Product Support** – Data sheets and errata, application notes and sample programs, design resources, user's guides and hardware support documents, latest software releases and archived software
- **General Technical Support** – Frequently Asked Questions (FAQs), technical support requests, online discussion groups, Microchip consultant program member listing
- **Business of Microchip** – Product selector and ordering guides, latest Microchip press releases, listing of seminars and events, listings of Microchip sales offices, distributors and factory representatives

DEVELOPMENT SYSTEMS CUSTOMER CHANGE NOTIFICATION SERVICE

Microchip's customer notification service helps keep customers current on Microchip products. Subscribers will receive e-mail notification whenever there are changes, updates, revisions or errata related to a specified product family or development tool of interest.

To register, access the Microchip web site at www.microchip.com, click on Customer Change Notification and follow the registration instructions.

The Development Systems product group categories are:

- **Compilers** – The latest information on Microchip C compilers, assemblers, linkers and other language tools. These include all MPLAB C compilers; all MPLAB assemblers (including MPASM assembler); all MPLAB linkers (including MPLINK object linker); and all MPLAB librarians (including MPLIB object librarian).
- **Emulators** – The latest information on Microchip in-circuit emulators. This includes the MPLAB REAL ICE and MPLAB ICE 2000 in-circuit emulators.
- **In-Circuit Debuggers** – The latest information on the Microchip in-circuit debuggers. This includes MPLAB ICD 3 in-circuit debuggers and PICKit 3 debug express.
- **MPLAB IDE** – The latest information on Microchip MPLAB IDE, the Windows Integrated Development Environment for development systems tools. This list is focused on the MPLAB IDE, MPLAB IDE Project Manager, MPLAB Editor and MPLAB SIM simulator, as well as general editing and debugging features.
- **Programmers** – The latest information on Microchip programmers. These include production programmers such as MPLAB REAL ICE in-circuit emulator, MPLAB ICD 3 in-circuit debugger and MPLAB PM3 device programmers. Also included are nonproduction development programmers such as PICSTART Plus and PIC-kit 2 and 3.

CUSTOMER SUPPORT

Users of Microchip products can receive assistance through several channels:

- Distributor or Representative
- Local Sales Office
- Field Application Engineer (FAE)
- Technical Support

Customers should contact their distributor, representative or field application engineer (FAE) for support. Local sales offices are also available to help customers. A listing of sales offices and locations is included in the back of this document.

Technical support is available through the web site at:

<http://www.microchip.com/support>

DOCUMENT REVISION HISTORY

Revisions	Section/Figure/Entry	Correction
DS50003566A (08-30-23)	Initial release	

Chapter 1. Overview

1.1 INTRODUCTION

The EVB-LAN8770-RGMII Evaluation Board is a plug-in card that interfaces directly with a mating Microchip host processor controller board, such as the SAMA5D3 Ethernet Development System (EDS) board. It features the EVB-LAN8770, a highly integrated networking device that incorporates a 100BASE-T1 physical layer transceiver (PHY). The board's PHY port is connected to a RJ45 Ethernet jack with integrated magnetics, and the PHY's RGMII connections are brought out to a high-speed multi-pin (HS) connector.

Together, the EVB-LAN8770-RGMII Evaluation Board and the SAMA5D3-EDS provide a highly-flexible platform for evaluation of basic PHY features via static Control-Status Registers (CSR).

The scope of this document is meant to describe the EVB-LAN8770-RGMII Evaluation Board setup and its user interface features. A simplified block diagram of the board is shown in [Figure 1-1](#).

1.2 BLOCK DIAGRAM

FIGURE 1-1: EVB-LAN8770-RGMII BLOCK DIAGRAM

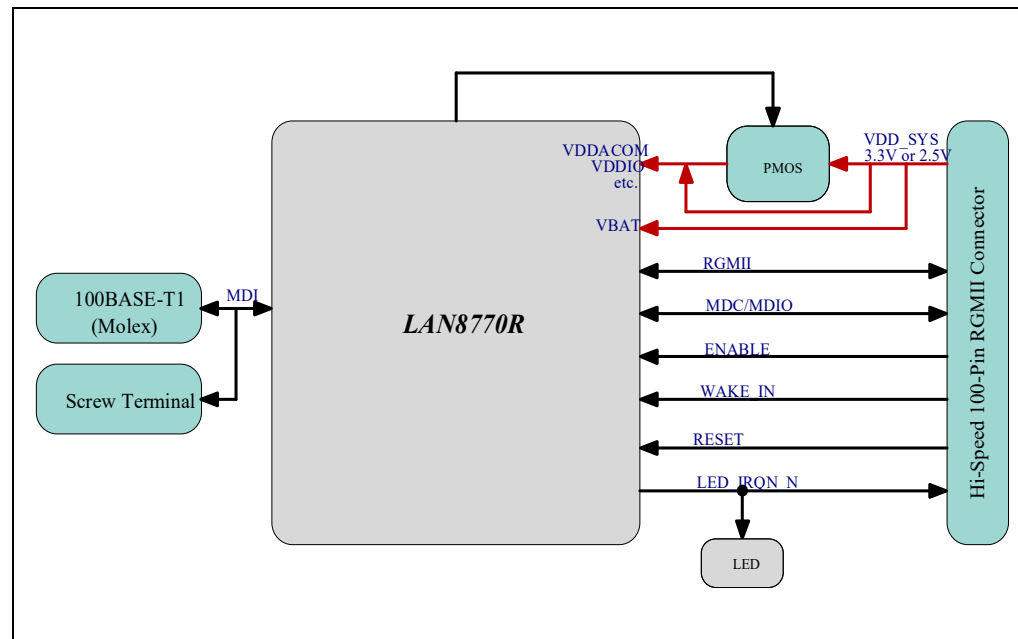

1.3 REFERENCES

Concepts and materials available in the following documents may be helpful when reading this document. Visit www.microchip.com for the latest documentation.

- *LAN8770 Data Sheet*
- LAN8770 Schematics
- SAMA5D3 Ethernet Development System Schematics
- *SAMA5D3 Ethernet Development System Board User's Guide*
- *EVB-LAN7431-EDS Board User's Guide*
- *EVB-LAN7801-EDS Board User's Guide*
- *MIC94052 Data Sheet*
- *VXM7-9013 Data Sheet*

1.4 TERMS AND ABBREVIATIONS

The following are the terms and abbreviations used in this document:

- CSR – Control Status Registers
- DNP – Do Not Populate
- EDS – Ethernet Development System
- EEPROM – Electronically Erasable Programmable Read-Only Memory
- MDC – Management Data Clock
- MDIO – Management Data Input/Output
- PHY – Physical Layer Transceiver
- RGMII – Reduced Gigabit Media Independent Interface
- SMI – Serial Management Interface

Chapter 2. Getting Started

2.1 INTRODUCTION

The EVB-LAN8770-RGMII Evaluation Board is designed as a plug-in card to interface directly with a mating Microchip host processor or controller board, such as the SAMA5D3-EDS Board, that supplies full power and provides full register access and configuration via MDIO/MDC bus management.

2.2 DEFAULT JUMPER SETTINGS

The EVB-LAN8770-RGMII ships with the necessary jumpers installed for basic operation. These are:

- J5: shunt installed between pins [1-2]
- J15: shunt installed between pins [1-2]
- J16: shunt installed between pins [2-3]
- J18: shunt installed between pins [1-2]

See [Figure 3.2](#) for an image of these default shunt installations.

See [Section 3.4 “Connectors”](#) for a full list of connector/header descriptions and directions for use.

2.3 POWER SOURCE

The EVB-LAN8770-RGMII can be completely bus-powered from its mating Microchip host processor or control board. Alternatively, the EVB-LAN8770-RGMII can be powered with an external 3.3V supply.

Refer to [Figure 3.2](#) and the board schematics in [Figure A-1](#) for details.

2.3.1 EDS-Powered Operation

For EDS-powered operation:

- J16 needs a jumper on either pins [1-2] for 2.5V operation or pins [2-3] for 3.3V operation.
- Either one of the following two options but not both options:
 - J15 [1-2] for normal operation
 - J13 [1-2] for TC10 application where INH controls non-VBAT power supplies

2.3.2 External-Powered Operation

For external-powered operation:

- Apply 2.5V or 3.3V to J16, pin 2 (center pin).
- Either one of the following two options but not both options:
 - J15 [1-2] for normal operation
 - J13 [1-2] for TC10 application where INH controls non-VBAT power supplies

2.4 CLOCK

The EVB-LAN8770-RGMII utilizes a 25 MHz crystal to generate input reference clock for the LAN8770 device. Refer to [Figure A-1](#) for details.

2.5 RESET CIRCUIT

2.5.1 Power-On Reset—EDS Reset

The SAMA5D3-EDS can provide the LAN8770 Reset when a jumper is placed on EVB-LAN8770, J18 pins [2-3] (EDS Reset).

2.5.2 Manual Reset

The EVB-LAN8770 SW1 can be pressed and released to provide LAN8770 Reset after device power-up. The EVB-LAN8770-RGMII J18 must have a jumper between pins [1-2] (onboard) to use this manual Reset.

2.6 USING THE EVB-LAN8770-RGMII

2.6.1 With SAMA5D3-EDS

The EVB-LAN8770-RGMII directly plugs into a mating Microchip host controller or processor board, such as the SAMA5D3-EDS, that can deliver full power and provide full register access and configuration via MDIO/MDC bus management.

Together, the EVB-LAN8770 and the SAMA5D3-EDS enable 100 Mbps Ethernet traffic through RGMII and the PHY port of the EVB-LAN8770 device, with the RGMII port connecting to the SAMA5D3 processor and the PHY port connecting via copper Ethernet cable (CAT-5 UTP or better) to external Ethernet devices.

All LAN8770 registers are accessible via MDIO/MDC bus management from the SAMA5D3-EDS Board, enabling full evaluation and firmware for all LAN8770 features. Refer to the *SAMA5D3 Ethernet Development System Board User's Guide*. [Figure 2-1](#) shows the EVB-LAN8770-RGMII connected to the SAMA5D3-EDS board.

FIGURE 2-1: EVB-LAN8770-RGMII AND SAMA5D3-EDS BOARD (TOP VIEW)

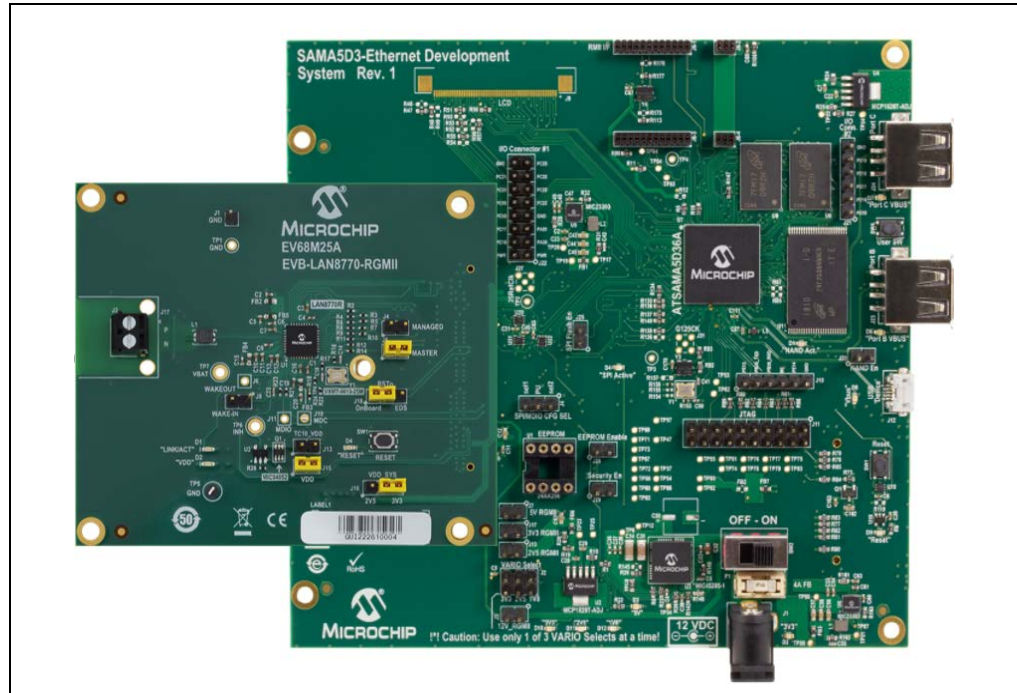

2.6.2 With EVB-LAN7431-EDS

For EVB-LAN7431-EDS to work with the EVB-LAN8770, a specific LAN7431 EEPROM image should be programmed onto the EVB-LAN7431-EDS baseboard. This is necessary to ensure that RGMII TXC and RXC delays settings are appropriately configured, and the LAN7431's 125 MHz clock source is enabled. A `readme` file that describes the detailed configuration and the binary files used to program the EVB-LAN7431-EDS is available on the EVB-LAN8770-RGMII Evaluation Board product page.

All LAN8770 registers are accessible via MDIO/MDC bus management from the EVB-LAN7431-EDS (through both Windows[®] and Linux[®]), enabling full evaluation.

2.6.3 With EVB-LAN7801-EDS

For EVB-LAN7801-EDS to work with the EVB-LAN8770, a specific LAN7801 EEPROM image should be programmed onto the EVB-LAN7801-EDS baseboard. This is necessary to ensure that RGMII TXC and RXC delay settings are appropriately configured, and the LAN7801's 125 MHz clock source is enabled.

A `readme` file that describes the detailed configuration and the binary files used to program the EVB-LAN7801-EDS are available on the EVB-LAN8770-RGMII Evaluation Board product page.

All LAN8770 registers are accessible via MDIO/MDC bus management, enabling full LAN8770 evaluation through either of these methods:

- EVB-LAN7801-EDS with Windows or Linux
 - Populate EVB-LAN7801-EDS J15 (MDC).
 - Populate EVB-LAN7801-EDS J16 (MDIO).
- EVB-LAN8770-RGMII
 - DNP EVB-LAN7801-EDS J15 (MDC).

EVB-LAN8770-RGMII Evaluation Board User's Guide

- DNP EVB-LAN7801-EDS J16 (MDIO).
- EVB-LAN8770-RGMII J10 (MDC) and J11 (MDIO) for local LAN8770 evaluation with a Serial Management Interface (SMI) tool

Chapter 3. Hardware Configuration

3.1 HARDWARE CONFIGURATION OPTIONS

Figure 3-1 shows the top view of the EVB-LAN8770-RGMII.

FIGURE 3-1: EVB-LAN8770-RGMII TOP VIEW WITH CALLOUTS

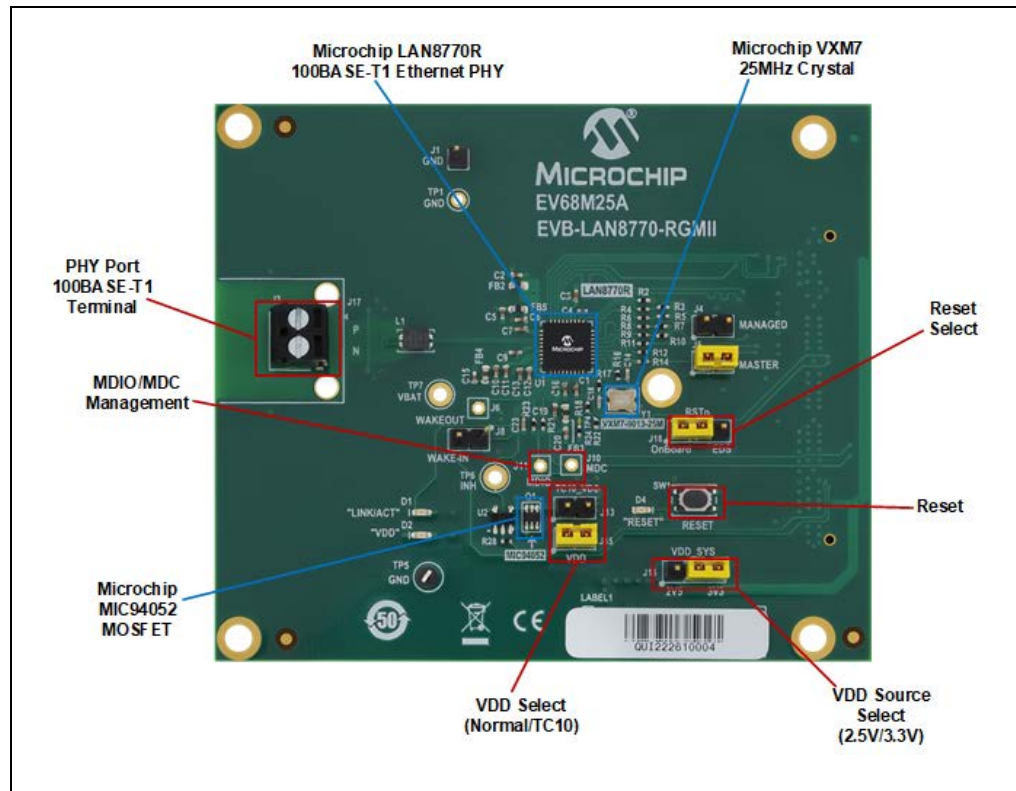

3.2 PHY PORT

PHY port (J17) supports 100BASE-T1 operation.

3.3 TEST POINTS

Table 3-1 lists the test points on the EVB-LAN8770-RGMII:

TABLE 3-1: TEST POINTS

Test Point	Description
J1	GND
TP1	GND
TP5	GND
TP6	INH
TP7	VBAT

3.4 CONNECTORS

Table 3-2 lists the connectors on the EVB-LAN8770-RGMII:

TABLE 3-2: CONNECTORS

Connector Reference Designator	Function	Options
J4	MANAGED mode Selection	Closed: LAN8770 is in Managed mode. Open: LAN8770 is in Autonomous mode.
J5	MASTER mode Selection	Closed: LAN8770 is configured as a leader. Open: LAN8770 is configured as a follower.
J8	WAKEIN Jumper	Closed: Allows LAN8770 WAKE_IN access to MAC through J14 RGMII connector. Open: LAN8770 WAKE_IN is isolated from MAC.
J10	MDC Header	N/A
J11	MDIO Header	N/A
J13	TC10_VDD Select	If populated, VDD power is NOT applied to non-VBAT supplies in TC10 Sleep mode. (See Note 1 .)
J14	RGMII Connector	N/A
J15	VDD Jumper	If populated, VDD power is delivered on non-VBAT supplies in TC10 Sleep mode. (See Note 1 .)
J16	VDD_SYS Select	Shunt pins [1-2]: VDD_SYS is 2.5V. Shunt pins [2-3]: VDD_SYS is 3.3V. (See Note 2 .)
J17	100BASE-T1 Ethernet Connector	N/A
J18	RESET Select	Shunt pins [1-2]: Reset comes from MAC (EDS) device. Shunt pins [2-3]: Reset comes from local Reset button (SW1).

Note 1: Only one of J13 or J15 must be populated for LAN8770 power.

Note 2: A shunt must be placed on either [1-2] or [2-3] for LAN8770 power.



Appendix A. Schematics

A.1 INTRODUCTION

This appendix shows the EVB-LAN8770-RGMII Evaluation Board schematics.

FIGURE A-1: EVB-LAN8770-RGMII SCHEMATIC 1

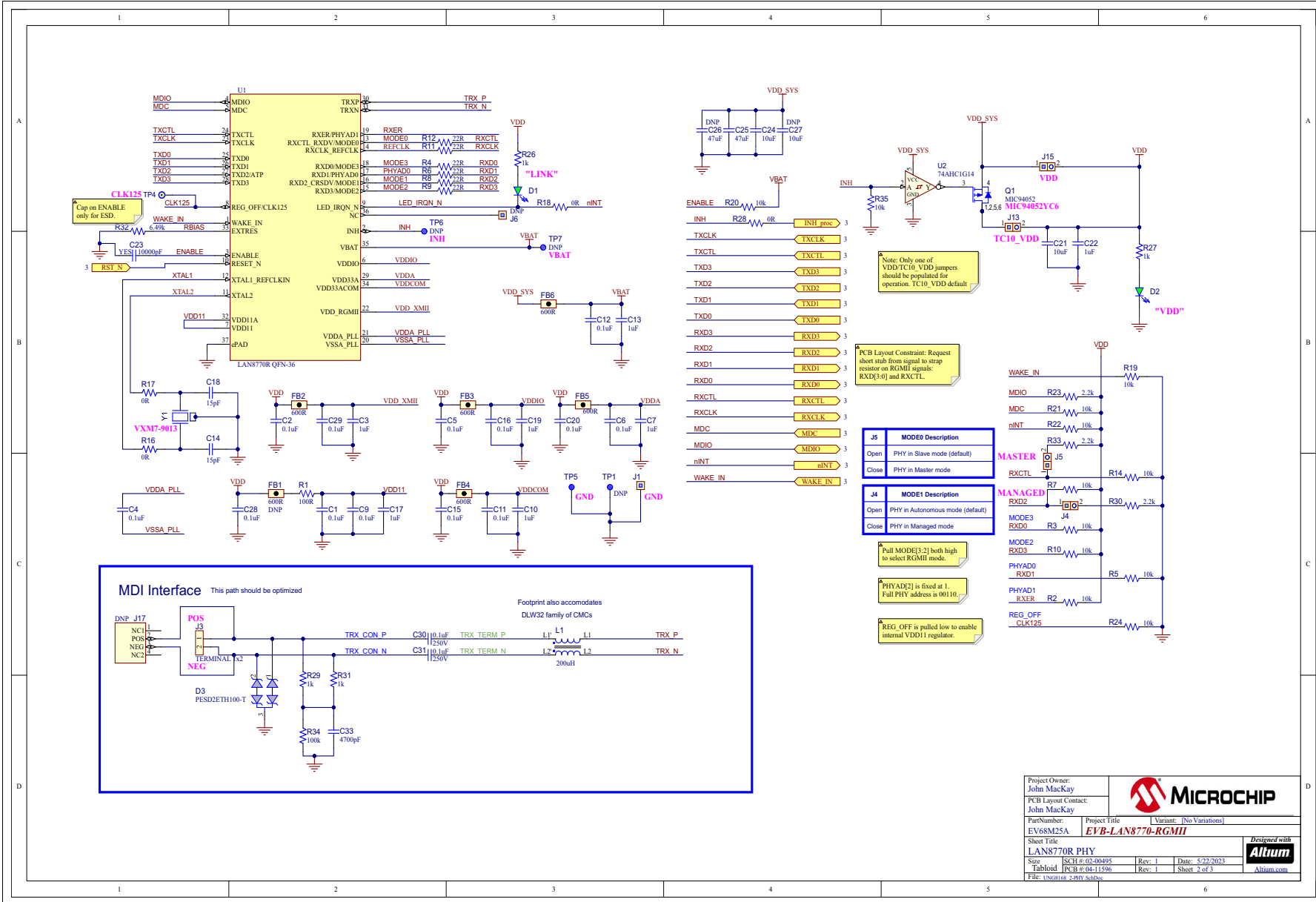

Project Owner: John MacKay
 PCB Layout Contact: John MacKay

Part Number: EV68M25A
 Project Title: EVB-LAN8770-RGMII
 Variant: [No Variations]

Sheet Title: LANS8770R PHY

Size: SCH #: 02-00495 Rev: 1 Date: 5/22/2023
 Tabloid: PCB #: 04-11596 Rev: 1 Sheet: 2 of 3

File: ucxarus_2PHY_Schms

Designed with Altium

FIGURE A-2: EVB-LAN8770-RGMII SCHEMATIC 2

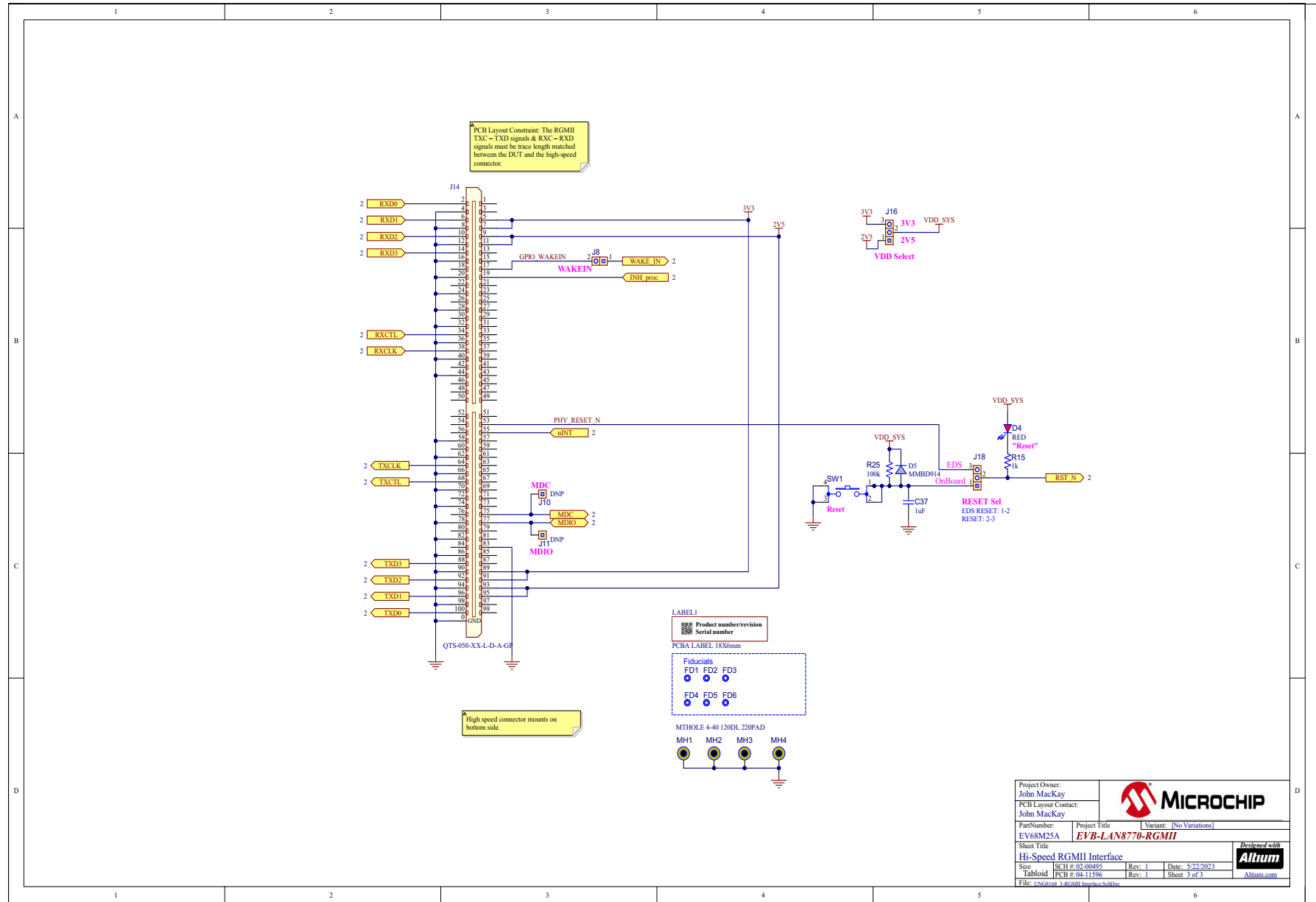

Project Owner: John MacKay		
PCB Layout Contact: John MacKay		
Part Number: EV68M25A	Project Title: EVB-LAN8770-RGMII	Variant: (No Variations)
Sheet Title: Hi-Speed RGMII Interface		
Size: Tabloid	SCH #: 02-00495 PCB #: 04-11596	Rev: 1 Rev: 1
Date: 5/22/2023		Sheet: 3 of 3
File Location: Schematics/EVB-LAN8770-RGMII		Designed with

EVB-LAN8770-RGMII Evaluation Board User's Guide

NOTES:



Appendix B. Bill of Materials

B.1 INTRODUCTION

This appendix contains the EVB-LAN8770-RGMII Evaluation Board Bill of Materials (BOM).

TABLE B-1: EVB-LAN8770 RGMII BILL OF MATERIALS

Item	Quantity	Designator	Description	Populated	Manufacturer	Manufacturer Part Number
1	13	C1, C2, C4, C5, C6, C9, C11, C12, C15, C16, C20, C28, C29	CAP CER 0.1uF 35V 10% X7R SMD 0402	YES	TDK Corporation	CGA2B3X7R1V104K050BB
2	7	C3, C7, C10, C13, C17, C19, C22	CAP CER 1uF 35V 10% X5R SMD 0402	YES	Murata Electronics North America	GRM155R6YA105KE11D
3	2	C14, C18	CAP HiQ 15pF 50V 5% NP0 2.32GHz SMD 0402	YES	Johanson Technology Inc	500R07S150JV4T
4	2	C21, C24	CAP CER 470pF 25V 5% NP0 SMD 0603	YES	Murata Electronics North America	GRM188R61E106MA73D
5	1	C23	CAP CER 10000pF 16V 10% X7R SMD 0402	YES	KEMET	C0402C103K4RACTU
6	1	C25	CAP CER 47uF 6.3V 20% X5R SMD 0805v	YES	Taiyo Yuden	JMK212BJ476MG-T
7	2	C30, C31	CAP CER 0.1uF 250V 10% X7T SMD 0805	YES	TDK Corporation	C2012X7T2E104K125AA
8	1	C33	CAP CER 4700pF 250V 10% X7R SMD 0805	YES	KEMET	C0805C472KARACAUTO
9	1	C37	CAP CER 1uF 16V 10% X5R SMD 0603	YES	AVX	0603YD105KAT2A
10	1	D1, D2	DIO LED GREEN 2V 30mA 35mcd Clear SMD 0603	YES	Lite-On Inc	LTST-C191KGKT
11	1	D3	DIO TVS ARRAY PESD2ETH100-TR 24V SMD SOT-23-3	YES	Nexperia	PESD2ETH100-TR
12	5	FB2, FB3, FB4, FB5, FB6	FERRITE 600R 500mA SMD 0603	YES	Murata Electronics North America	BLM18AG601SH1D
13	1	J1	CON HDR-2.54 Male 1x1 Gold 5.84MH TH VERT	YES	TE Connectivity	5-146280-1
14	1	J3	CON TERMINAL 3.5mm 1x2 Female 16-26AWG 10A TH R/A	YES	On Shore Technology Inc.	OSTTE020104
15	5	J4, J5, J8, J13, J15	CON HDR-2.54 Male 1x2 Gold 5.84MH TH VERT	YES	FCI	68001-202HLF
16	1	J14	CON STRIP High Speed Stacker 5mm Male 2x50 SMD VERT	YES	Samtec	QTS-050-01-L-D-A-GP
17	2	J16, J18	CON HDR-2.54 Male 1x3 Gold 5.84MH TH VERT	YES	FCI	68000-103HLF
18	1	L1	CM CHOKE 5.5R@100kHz 200UH SMD 3.2X2.5MM	YES	TDJK Electronics	DLW43MH201XK2L
19	1	Q1	MCHP ANALOG MOSFET SINGLE P-CH MIC94052YC6 2A 0.270WSC70-6	YES	Microchip Technology	MIC94052YC6-TR
20	1	R1	RES TKF 100R 1% 1/10W SMD 0402	YES	Panasonic Electronic Components	ERJ-2RKF1000X
21	12	R2, R3, R5, R7, R10, R14, R19, R20, R21, R22, R24, R35	RES TKF 10k 1% 1/10W SMD 0402	YES	Panasonic	ERJ-2RKF1002X
22	6	R4, R6, R8, R9, R11, R12	RES TKF 22R 1% 1/16W SMD 0402	YES	Yageo	RC0402FR-0722RL
23	3	R15, R26, R27	RES TKF 1k 5% 1/16W SMD 0402	YES	Yageo	RC0402JR-071KL
24	4	R16, R17, R18, R28	RES TKF 0R SMD 0402 AEC-Q200	YES	Panasonic	ERJ-2GE0R00X
25	3	R23, R30, R33	RES TKF 2.2k 5% 1/16W SMD 0402	YES	Vishay Dale	CRCW04022K20JNED
26	1	R25	RES TF 100k 1% 1/10W SMD 0603	YES	Yageo	RC0603FR-07100KL

TABLE B-1: EVB-LAN8770 RGMII BILL OF MATERIALS (CONTINUED)

Item	Quantity	Designator	Description	Populated	Manufacturer	Manufacturer Part Number
27	2	R29, R31	RES TF 1k 1% 1/2W SMD 1206	YES	Stackpole Electronics Inc	RNCP1206FTD1K00
28	1	R32	RES TkF 6.49k 0.1% 1/16W SMD 0402	YES	Panasonic Electronics Components	ERA-2ARB6491X
29	1	R34	RES TKF 100k 1% 1/4W SMD 0603	YES	Vishay	CRCW0603100KFKEAHP
30	1	SW1	SWITCH TACT SPST-NO 16V 0.05A PTS810 SMD	YES	C&K Components	PTS810 SJM 250 SMTR LFS
31	1	TP5	CON TP LOOP Black 3.18x5.59 TH	YES	Keystone Electronics	5006
32	1	U1	MCHP INTERFACE T1 ETHERNET LAN8770R QFN-36	YES	Microchip Technology	LAN8770R-E/5KXVAO
33	1	U2	C BUFFER Inverting Schmitt trigger 74AHC1G14GV GATE SGL CMOS SOT-23-5	YES	Nexperia	74AHC1G14GV,125
34	1	Y1	MCHP CRYSTAL 25Mhz 10pF SMD L3.2W2.5H0.8	YES	Microchip Technology	VXM7-9013-25M0000000
35	1	C26	CAP CER 47uF 6.3V 20% X5R SMD 0805	DNP	Taiyo Yuden	JMK212BJ476MG-T
36	1	C27	CAP CER 10uF 25V 20% X5R SMD 0603	DNP	Murata Electronics North America	GRM188R61E106MA73D
37	1	FB1	FERRITE 600R 500mA SMD 0603	DNP	Murata Electronics North America	BLM18AG601SH1D
38	3	J6, J10, J11	CON HDR-2.54 Male 1x1 Gold 5.84MH TH VERT	DNP	TE Connectivity	5-146280-1
39	1	J17	CON JACK MINI50 2MM BLACK MALE TH R/A	DNP	Molex, LLC	0347930040
40	1	TP1	MISC, TEST POINT MULTI PURPOSE MINI BLACK	DNP	Keystone	5001
41	2	TP6, TP7	CON TP LOOP Black 3.18x5.59 TH	DNP	Keystone Electronics	5006



MICROCHIP

Worldwide Sales and Service

AMERICAS

Corporate Office
2355 West Chandler Blvd.
Chandler, AZ 85224-6199
Tel: 480-792-7200
Fax: 480-792-7277
Technical Support:
<http://www.microchip.com/support>
Web Address:
www.microchip.com

Atlanta
Duluth, GA
Tel: 678-957-9614
Fax: 678-957-1455

Austin, TX
Tel: 512-257-3370

Boston
Westborough, MA
Tel: 774-760-0087
Fax: 774-760-0088

Chicago
Itasca, IL
Tel: 630-285-0071
Fax: 630-285-0075

Dallas
Addison, TX
Tel: 972-818-7423
Fax: 972-818-2924

Detroit
Novi, MI
Tel: 248-848-4000

Houston, TX
Tel: 281-894-5983

Indianapolis
Noblesville, IN
Tel: 317-773-8323
Fax: 317-773-5453
Tel: 317-536-2380

Los Angeles
Mission Viejo, CA
Tel: 949-462-9523
Fax: 949-462-9608
Tel: 951-273-7800

Raleigh, NC
Tel: 919-844-7510

New York, NY
Tel: 631-435-6000

San Jose, CA
Tel: 408-735-9110
Tel: 408-436-4270

Canada - Toronto
Tel: 905-695-1980
Fax: 905-695-2078

ASIA/PACIFIC

Australia - Sydney
Tel: 61-2-9868-6733

China - Beijing
Tel: 86-10-8569-7000

China - Chengdu
Tel: 86-28-8665-5511

China - Chongqing
Tel: 86-23-8980-9588

China - Dongguan
Tel: 86-769-8702-9880

China - Guangzhou
Tel: 86-20-8755-8029

China - Hangzhou
Tel: 86-571-8792-8115

China - Hong Kong SAR
Tel: 852-2943-5100

China - Nanjing
Tel: 86-25-8473-2460

China - Qingdao
Tel: 86-532-8502-7355

China - Shanghai
Tel: 86-21-3326-8000

China - Shenyang
Tel: 86-24-2334-2829

China - Shenzhen
Tel: 86-755-8864-2200

China - Suzhou
Tel: 86-186-6233-1526

China - Wuhan
Tel: 86-27-5980-5300

China - Xian
Tel: 86-29-8833-7252

China - Xiamen
Tel: 86-592-2388138

China - Zhuhai
Tel: 86-756-3210040

ASIA/PACIFIC

India - Bangalore
Tel: 91-80-3090-4444

India - New Delhi
Tel: 91-11-4160-8631

India - Pune
Tel: 91-20-4121-0141

Japan - Osaka
Tel: 81-6-6152-7160

Japan - Tokyo
Tel: 81-3-6880-3770

Korea - Daegu
Tel: 82-53-744-4301

Korea - Seoul
Tel: 82-2-554-7200

Malaysia - Kuala Lumpur
Tel: 60-3-7651-7906

Malaysia - Penang
Tel: 60-4-227-8870

Philippines - Manila
Tel: 63-2-634-9065

Singapore
Tel: 65-6334-8870

Taiwan - Hsin Chu
Tel: 886-3-577-8366

Taiwan - Kaohsiung
Tel: 886-7-213-7830

Taiwan - Taipei
Tel: 886-2-2508-8600

Thailand - Bangkok
Tel: 66-2-694-1351

Vietnam - Ho Chi Minh
Tel: 84-28-5448-2100

EUROPE

Austria - Wels
Tel: 43-7242-2244-39
Fax: 43-7242-2244-393

Denmark - Copenhagen
Tel: 45-4485-5910
Fax: 45-4485-2829

Finland - Espoo
Tel: 358-9-4520-820

France - Paris
Tel: 33-1-69-53-63-20
Fax: 33-1-69-30-90-79

Germany - Garching
Tel: 49-8931-9700

Germany - Haan
Tel: 49-2129-3766400

Germany - Heilbronn
Tel: 49-7131-72400

Germany - Karlsruhe
Tel: 49-721-625370

Germany - Munich
Tel: 49-89-627-144-0
Fax: 49-89-627-144-44

Germany - Rosenheim
Tel: 49-8031-354-560

Israel - Ra'anana
Tel: 972-9-744-7705

Italy - Milan
Tel: 39-0331-742611
Fax: 39-0331-466781

Italy - Padova
Tel: 39-049-7625286

Netherlands - Drunen
Tel: 31-416-690399
Fax: 31-416-690340

Norway - Trondheim
Tel: 47-7288-4388

Poland - Warsaw
Tel: 48-22-3325737

Romania - Bucharest
Tel: 40-21-407-87-50

Spain - Madrid
Tel: 34-91-708-08-90
Fax: 34-91-708-08-91

Sweden - Gothenberg
Tel: 46-31-704-60-40

Sweden - Stockholm
Tel: 46-8-5090-4654

UK - Wokingham
Tel: 44-118-921-5800
Fax: 44-118-921-5820