

Preface

The PIC32CM SG00/GC00 Curiosity Pro development board is a hardware platform which uses the PIC32CM5112SG00100 or the PIC32CM5112GC00100 microcontrollers. This development board provides easy access to the microcontroller features and can be used to develop custom applications.

The PIC32CM SG00/GC00 Curiosity Pro development board includes an integrated programmer or debugger and requires no additional hardware to get started. The development board comes pre-programmed with a demonstration application and uses power provided by its micro-USB connections.

The PIC32CM SG00/GC00 Curiosity Pro development board is shown below:

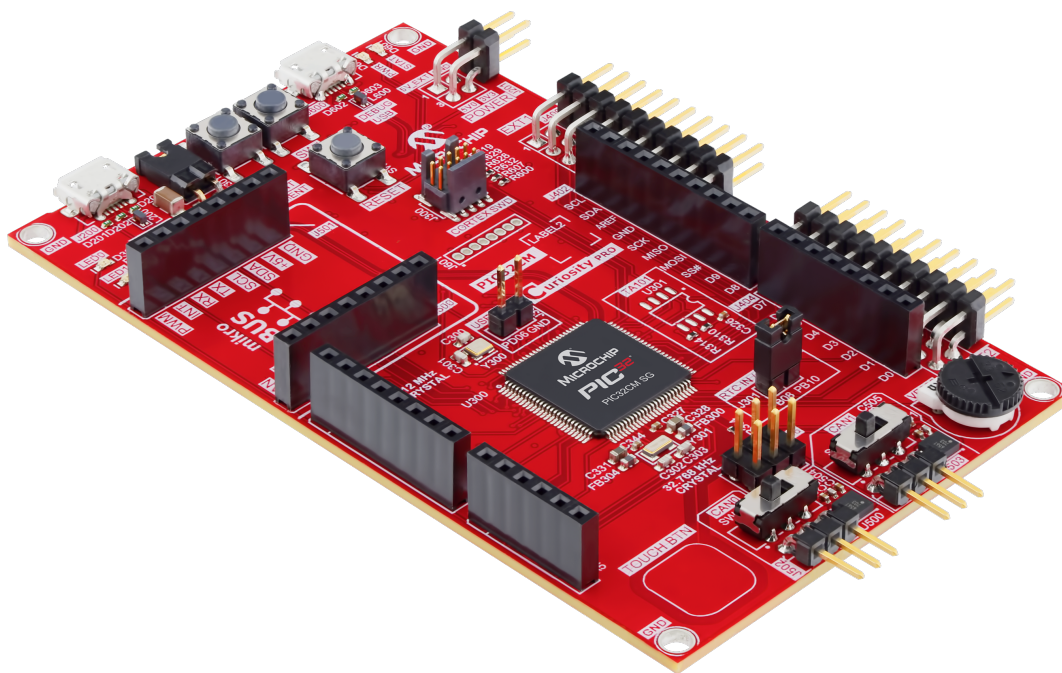

Table of Contents

Preface.....	1
1. Introduction.....	3
1.1. PIC32CM SG00/GC00 Curiosity Pro Development Board Features.....	3
1.2. Kit Contents.....	3
2. Getting Started.....	4
2.1. Curiosity Pro Quick Start	4
3. Development Board Functionality and Features.....	5
3.1. Board Feature Location.....	5
3.2. System Block Diagram.....	6
3.3. Power Sources.....	6
3.4. PIC32CM SG00/GC00 Microcontroller	8
3.5. Clock Circuitry.....	9
3.6. Extension Headers.....	10
3.7. Extension Power Header.....	13
3.8. mikroBUS Socket.....	13
3.9. Arduino UNO R3 Interface.....	14
3.10. CAN Transceivers.....	16
3.11. Security IC.....	17
3.12. 3.3V Voltage Reference.....	17
3.13. USB Interface.....	18
3.14. Buttons.....	18
3.15. User LEDs.....	19
3.16. USERLDO Header.....	19
3.17. Tamper Detection.....	20
3.18. 10 kOhms Potentiometer.....	20
3.19. SWD Debug Connector.....	20
3.20. MPLAB PICKit On-Board 4.....	20
4. Hardware.....	24
4.1. PIC32CM SG00/GC00 Curiosity Pro Schematics.....	24
4.2. PIC32CM SG00/GC00 Curiosity Pro Layout.....	31
4.3. Bill of Materials.....	35
5. Revision History.....	39
Microchip Information.....	40
Trademarks.....	40
Legal Notice.....	40
Microchip Devices Code Protection Feature.....	40

1. Introduction

This document describes the Microchip PIC32CM SG00/GC00 Curiosity Pro development board (EA51N28A/EA36K74A/EV53V42A/EV17V75A) features, functionality, and schematics. The development board includes an integrated programmer or debugger, and requires no additional hardware to get started. Users can expand functionality through Arduino UNO R3, mikroBUS™, or Expansion Headers.

With expansion boards, the PIC32CM SG00/GC00 Curiosity Pro development board provides the freedom to develop a variety of applications, including Bluetooth® audio, Internet of Things (IoT), robotics development, and Proof of Concept (POC) designs.



Tip: It is strongly recommended to use a grounding strap or similar ESD protective device when handling the board in hostile ESD environments, like offices with synthetic carpet. Avoid touching the component pins or any other metallic element on the board.

1.1. PIC32CM SG00/GC00 Curiosity Pro Development Board Features

The following are key features of the PIC32CM SG00/GC00 Curiosity Pro development board:

- PIC32CM5112SG00100 or PIC32CM5112GC00100, 72 MHz, 512 KB Flash, 128 KB SRAM
 - Up to 80 I/O lines with external interrupt capability
- On-board debugger (MPLAB® PICkit™ on-Board 4, PKOB4)
 - Real-time programming and debugging
 - Virtual COM port (VCOM)
 - Data Gateway Interface (DGI)
- Two Extension headers
- One Extension Power header
- One mikroBUS socket
- One Arduino UNO R3 compatible interface headers
- Two Host Controller Area Networks (CAN)
- One Full-Speed USB Micro-A/B
- Two user buttons
- Two user LEDs

1.2. Kit Contents

The kit contains either PIC32CM SG00 or PIC32CM GC00 Curiosity Pro development board (EA51N28A/EA36K74A/EV53V42A/EV17V75A). The kit offers a set of features that enables the user to get started with the PIC32CM SG00/GC00 peripherals instantly and to develop an understanding of how to integrate the device in their own design.

Note: If you are missing any part of the kit, contact a Microchip sales office for assistance. A list of Microchip offices for sales and service are provided on the last page of this document.

2. Getting Started

2.1. Curiosity Pro Quick Start

Users need to follow these steps to explore the Curiosity Pro platform:

1. Download MPLAB X IDE (free download at www.microchip.com/mplabx/).
2. Launch MPLAB X IDE.
3. Connect a USB cable (Micro-A/B) between the PC and the debug USB port on the kit.

When the Curiosity Pro development tool is connected to the computer for the first time, the operating system will install a software driver.

The drivers for the kit are included with MPLAB X IDE. The driver file supports both 32-bit and 64-bit versions of Microsoft® Windows® XP, Windows Vista®, Windows 7, Windows 8, and Windows 10.

The demonstration firmware application comes programmed on the Curiosity Pro development board. The project is also available in downloadable materials. Some general functions of the board are available to exercise in the programmed version.

3. Development Board Functionality and Features

The following sections cover functionality and features of the PIC32CM SG00/GC00 Curiosity Pro development board.

3.1. Board Feature Location

The development board layout is shown in the following figure.

Figure 3-1. PIC32CM SG00/GC00 Curiosity Pro development board (Top View)

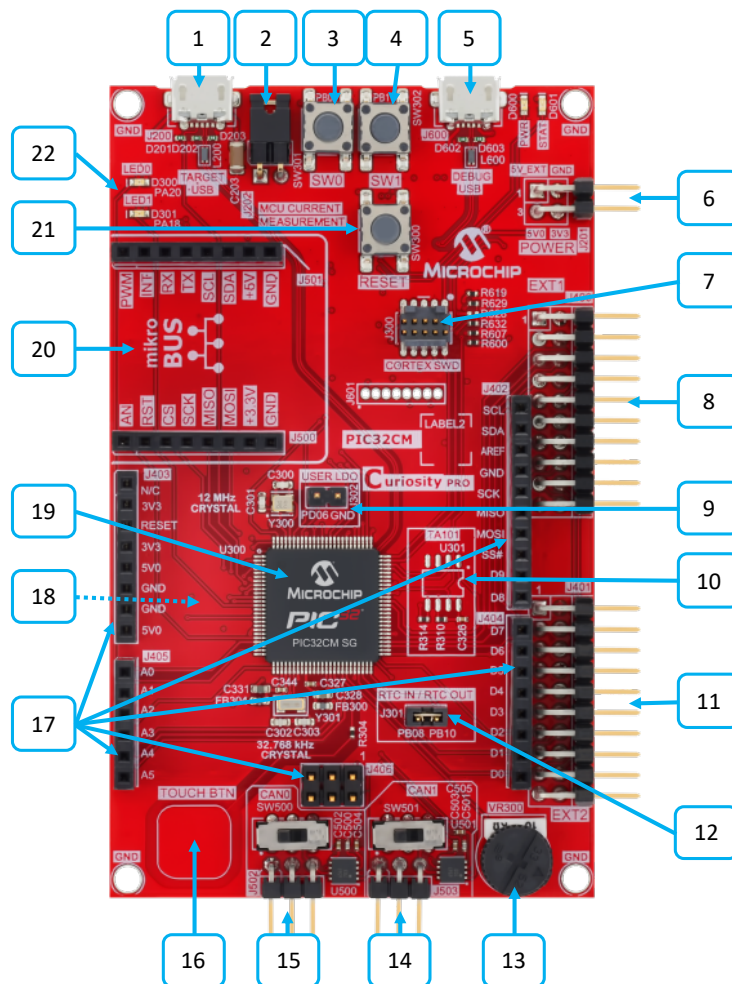

The following table provides the details and descriptions of the development board features.

Table 3-1. PIC32CM SG00/GC00 Curiosity Pro Development Board Features and Location

Number	Description of Item
1	Micro-USB Type-AB Host/Device DRD
2	MCU Current Measurement Jumper
3	User Switch 0
4	User Switch 1
5	Micro-USB Type-AB from PKOB4
6	Extension Power Header
7	Cortex® 10-pin Debug Interface

Table 3-1. PIC32CM SG00/GC00 Curiosity Pro Development Board Features and Location (continued)

Number	Description of Item
8	EXT1 Header
9	USERLDO Header
10	CryptoAuthentication device, TA101
11	EXT2 Header
12	RTC Header
13	10 kOhms Potentiometer
14	CAN1 Interface Header
15	CAN2 Interface Header
16	Touch Button
17	Arduino UNO R3 Shield Headers
18	3.3V High-Precision Voltage Reference (bottom side)
19	PIC32CM SG00/GC00 Microcontroller
20	mikroBUS Headers
21	Reset Switch
22	User LED0/LED1

3.2. System Block Diagram

The following figure illustrates a high-level block diagram of the PIC32CM SG00/GC00 Curiosity Pro development board.

Figure 3-2. PIC32CM SG00/GC00 Curiosity Pro System Block Diagram

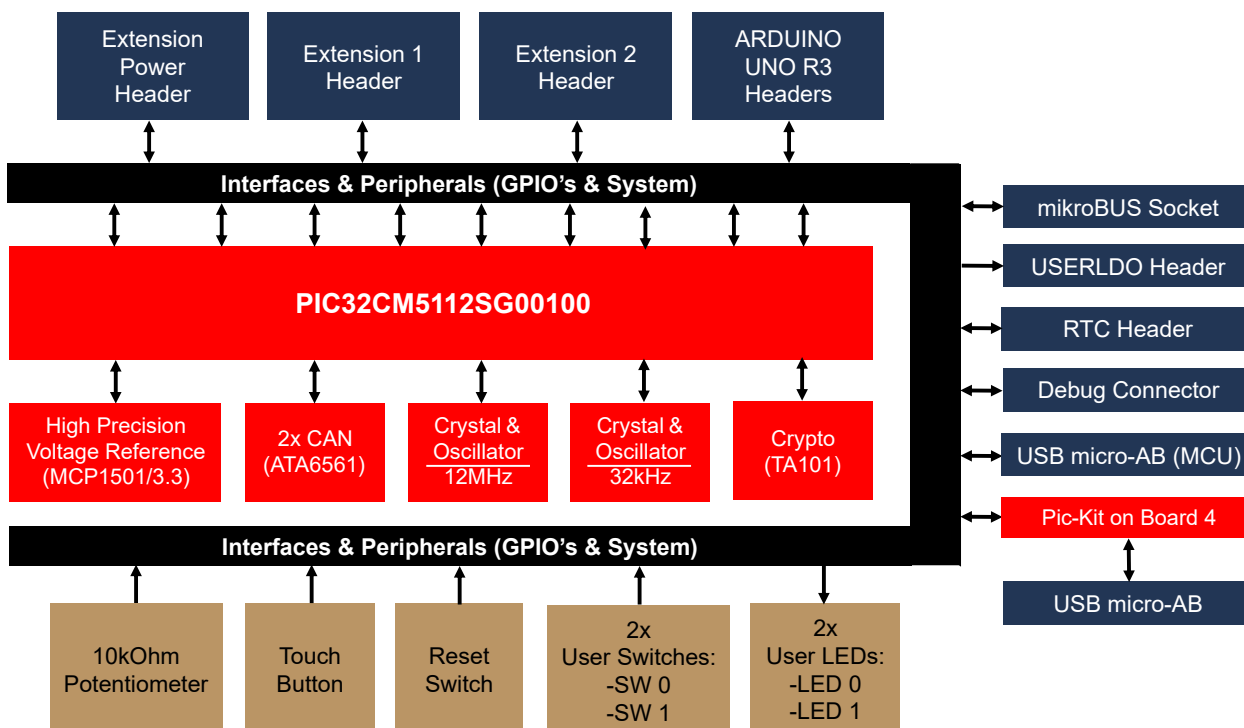

3.3. Power Sources

The PIC32CM SG00/GC00 Curiosity Pro kit can be powered by several power sources as listed in the following table:

Table 3-2. PIC32CM SG00/GC00 Curiosity Pro System Power Sources

Number	Power Source	Voltage Requirements	Current Requirements	Connector Marking
1	Embedded Debugger USB	From 4.75V to 5.25V DC (According to USB spec.)	500 mA (According to USB spec.)	DEBUG USB
2	Target USB	From 4.75V to 5.25V DC (According to USB spec.)	500 mA (According to USB spec.)	TARGET USB
3	External Power Header	5V DC $\pm 2\%$ (± 100 mV) for USB Host operation. From 4.3V to 5.5V DC if a USB Host operation is not required.	In those cases requiring current supply higher than 500 mA, this connector can be used to deliver up to 2A maximum.	POWER

The following figure illustrates a high-level block diagram of the power system on the PIC32CM SG01/GC01 Curiosity Pro development board.

Figure 3-3. PIC32CM SG00/GC00 Curiosity Pro Power Block Diagram

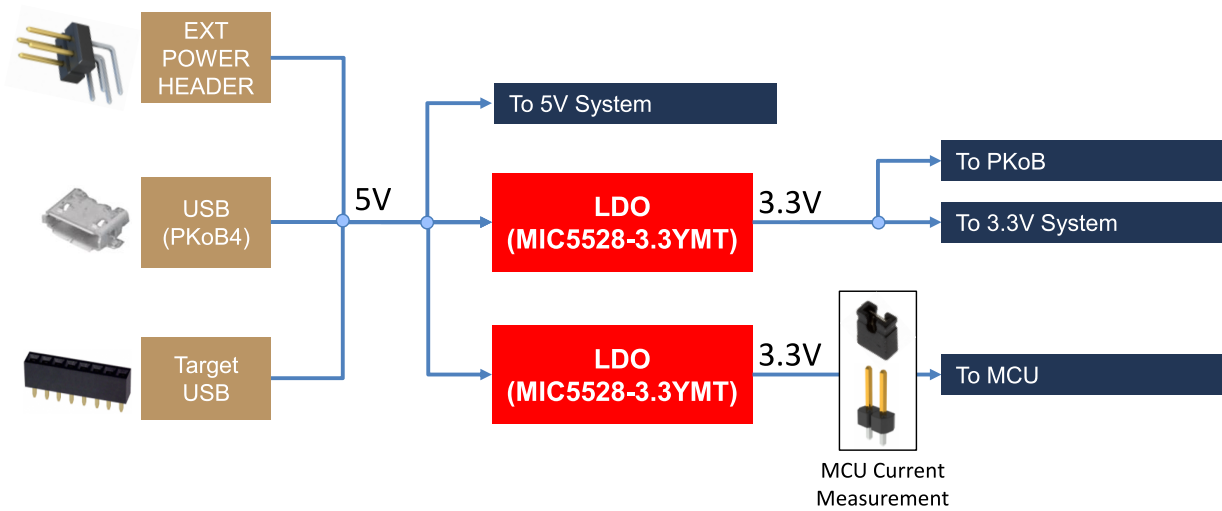
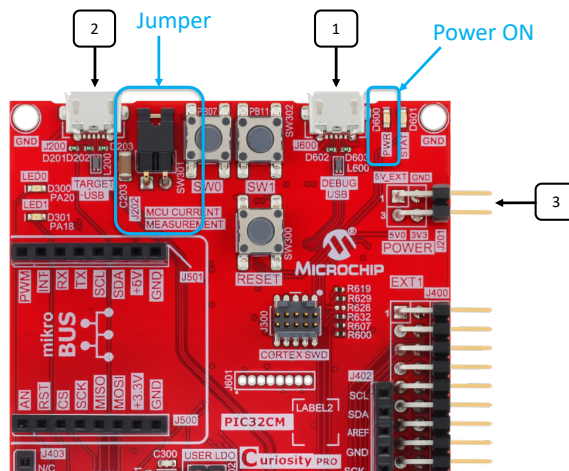

Figure 3-4. PIC32CM SG00/GC00 Curiosity Pro Power Inputs



Once the board is powered, the green LED D600 (PWR) is on.

Any of the three power sources provide 5V DC to supply two Low Dropout (LDO) regulators (MIC5528-3.3MYT) of 500 mA each one. They supply the PKOB4 debugger, the 3.3V system, and

the MCU target. For additional information about this LDO, refer to the “MIC5528 Data Sheet” (DS20005982) available at [product webpage](#).

Refer to the [Extension Power Header](#) for additional information about the Extension Power Header (J201).

The PIC32CM SG00/GC00 Curiosity Pro development board has a 1x2, 100 mil pitch pin header (J202) marked with *MCU Current Measurement* that is located at the upper edge of the board. All power to the target device is routed through this header and the header is populated with a jumper. The purpose of this header is to enable power consumption measurements of the target device with external equipment.

3.4. PIC32CM SG00/GC00 Microcontroller

The PIC32CM SG00/GC00 Curiosity Pro development board is based on the PIC32CM5112SG00100 or PIC32CM5112GC00100 device, which is a 72 MHz Arm® Cortex®-M23 processor with up to 512 KB Flash/w ECC, 32 KB SRAM, a 12-bit ADC module, an enhanced Peripheral Touch Controller and External Bus Interface (which can be used in some graphics applications), two CAN-FD modules, six Serial Communication interfaces (SERCOM) and one Full-Speed USB. The package assembled in the board is a 100-pin TQFP of 0.5 mm pitch.

The PIC32CM5112SG00100 device also features Trustzone and a full-secure enclave (HSM) for providing a high level of security.

The following figures illustrate the PIO schematic and power schematic.

Figure 3-5. PIC32CM SG00/GC00 PIO Schematic

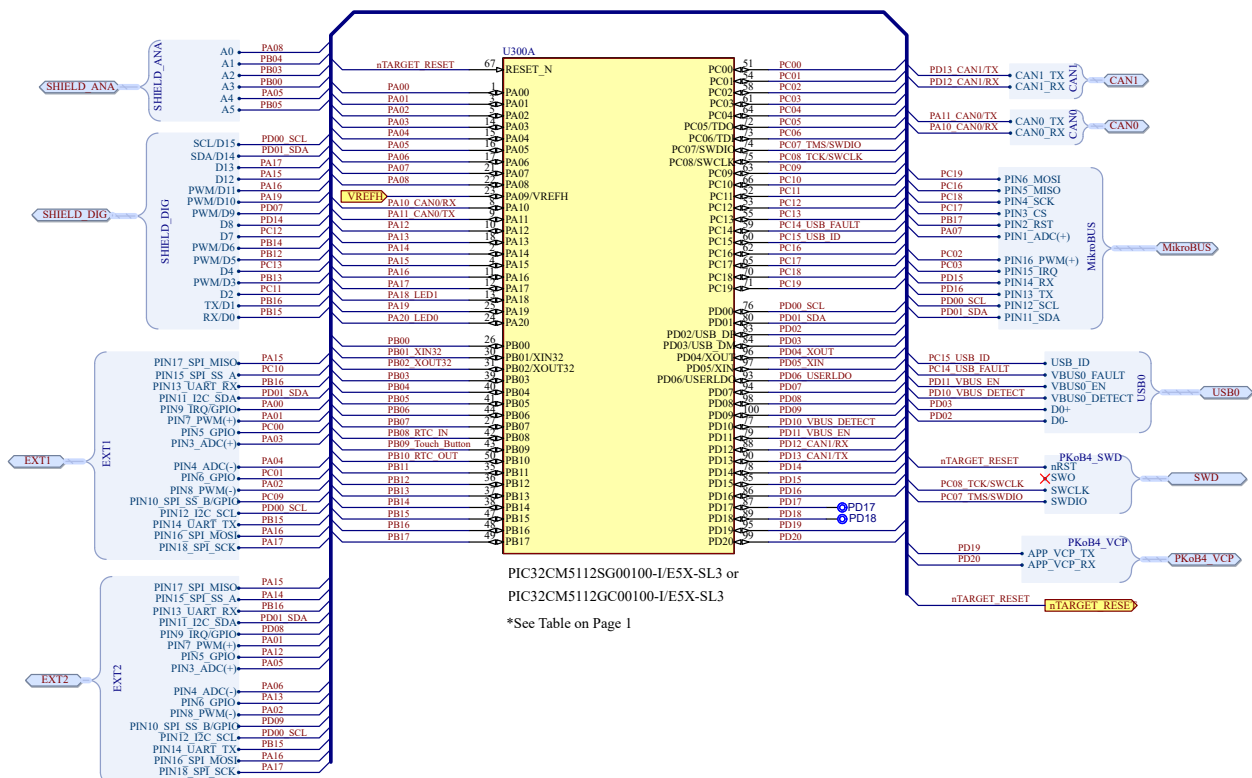
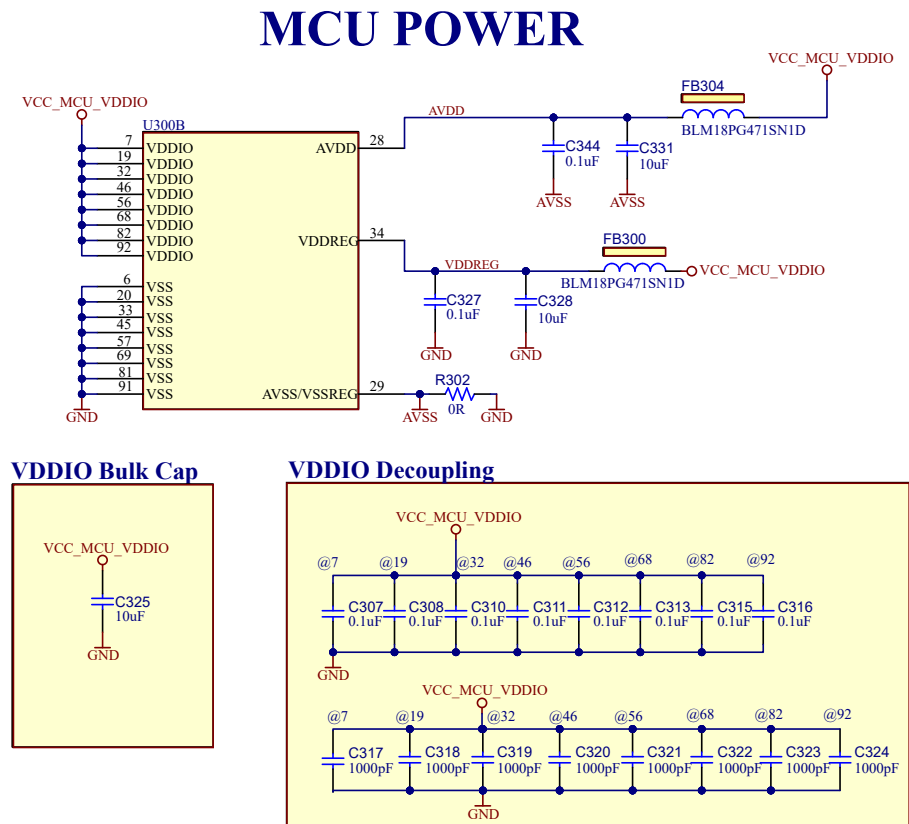

Figure 3-6. PIC32CM SG00/GC00 Power Schematic



Important:

The following component values must be optimized to see expected performance as is specified in the *Electrical Characteristics* chapter of the MCU data sheet:

- **FB304:** Change by a ferrite bead of at least 500 mA with a maximum value of DC Resistance of 0.1Ω and an impedance $\geq 600\Omega$ at 100 MHz
- **C325:** Change by a ceramic capacitor with a minimum value of 33 uF with ESR<0.5Ω
- **C328:** Change by a ceramic capacitor with a minimum value of 33 uF with ESR<0.5Ω
- **C332:** Change by a ceramic capacitor with a minimum value of 10 uF, X7R with ESR<0.5Ω

3.5. Clock Circuitry

The PIC32CM SG00/GC00 generates its necessary clocks based on a slow clock (SLCK) oscillator running at 32.768 kHz. By default, in the PIC32CM SG00/GC00 Curiosity Pro board a low-power 32.768 kHz crystal oscillator, Y303, is assembled. For additional information about this crystal, refer to the “VMK3-9005-32K7680000 Data Sheet” (DS20006440) available at [product webpage](#).

The PIC32CM SG00/GC00 provides a 32.768 kHz ultra-low power internal RC oscillator that can be used instead of the previous external crystal.

For evaluation purpose, the board also supports the use of a quartz crystal of 12 MHz (Y300) instead of using SLCK. For additional information about this crystal, refer to the “VXM8-9014-12M0000000 Data Sheet” available at [product webpage](#).

Figure 3-7. Microcontroller Crystal's Schematic

32.768 kHz Crystal

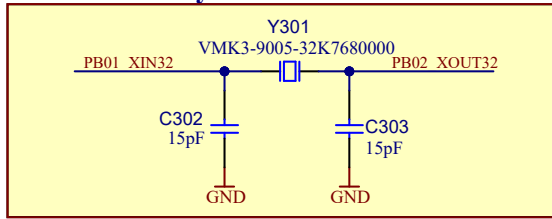

12 MHz Crystal

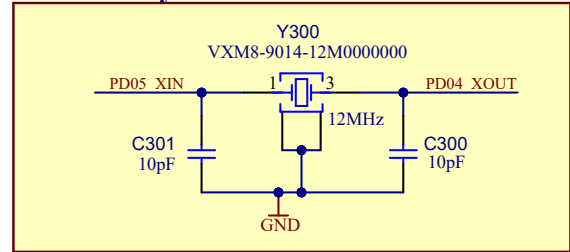

In addition to both crystal options for those frequencies, also available the Y302 and Y303 footprints to solder the following oscillators, featuring part numbers DSC6011J13B-032K768 and DSC1001DI5-012.0000. For additional information about these oscillators, refer to the "DSC6011J13B-032K768 Data Sheet" (DS20006133) and "DSC1001DI5-012.0000 Data Sheet" (DS20005529) available for download at [product webpage](#).

Figure 3-8. Microcontroller Oscillator's Schematic

12 MHz Oscillator

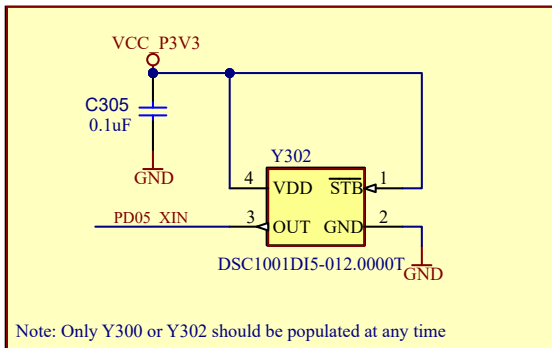

32.768 kHz Oscillator

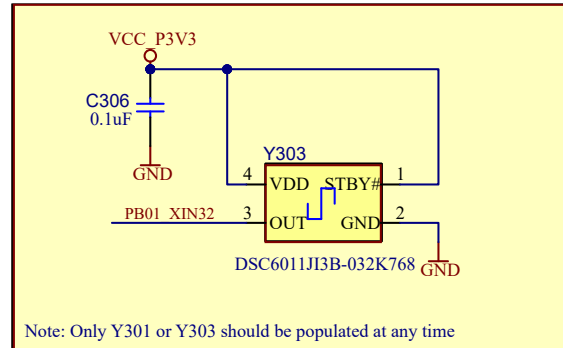

3.6. Extension Headers

The PIC32CM SG00/GC00 Curiosity Pro development board has two Extension headers, J400 and J401, which are Xplained Pro compatible interfaces that enable the use of existing expansion boards. Each interface consists of a dual-row, 20-pin, 100 mil pitch, right angle male header, while Xplained Pro extensions have their female counterparts. The Extension headers can be used to connect a variety of Xplained Pro extension boards or to access the pins of the target MCU directly, and some of these pins are shared between both Extension headers and even Arduino UNO R3 headers and mikroBUS socket.

Figure 3-9. EXT1 Extension Header (J400) Schematic

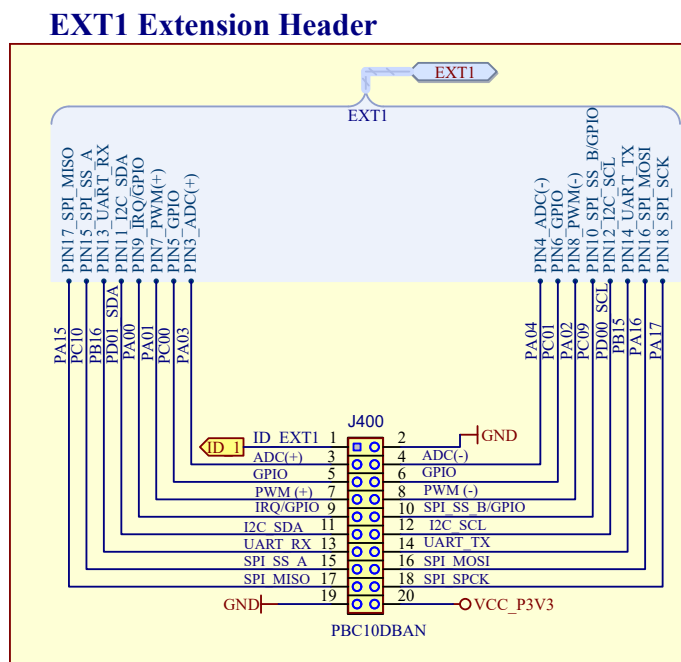

Table 3-3. Extension Header1 Pin Assignment

Pin Number	Pin Name	Description	GPIO
1	ID	Communication line to the ID chip on an extension board	-
2	GND	Ground	GND
3	ADC(+)	Analog-to-Digital converter, alternatively positive part of differential ADC	PA03
4	ADC(-)	Analog-to-Digital converter, alternatively negative part of differential ADC	PA04
5	GPIO1	General purpose I/O	PC00
6	GPIO2	General purpose I/O	PC01
7	PWM(+)	Pulse-Width Modulation, alternatively positive part of differential PWM	PA01
8	PWM(-)	Pulse-Width Modulation, alternatively negative part of differential PWM	PA02
9	IRQ/GPIO	Interrupt request line and/or general purpose I/O	PA00
10	SS/GPIO	Client select for SPI and/or general purpose I/O	PC09
11	TWD	Data line for I ² C interface. Always implemented, bus type	PD01
12	TWCK	Clock line for I ² C interface. Always implemented, bus type	PD00
13	RXD	Receiver line of target device UART	PB16
14	TXD	Transmitter line of target device UART	PB15
15	SS	Client select for SPI, should preferably be unique	PC10
16	MOSI	Host out Client in line of Serial Peripheral Interface	PA16
17	MISO	Host in Client out line of Serial Peripheral Interface	PA15
18	SCK	Clock for Serial Peripheral Interface	PA17
19	GND	Ground	GND
20	VCC	Power for extension board	VCC_P3V3

Figure 3-10. EXT2 Extension Header (J401) Schematic

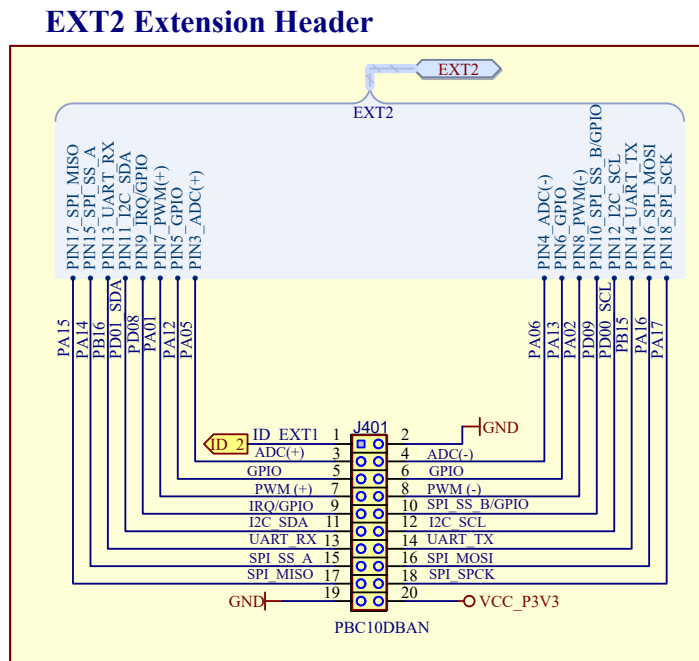

Table 3-4. Extension Header 2 Pin Assignment

Pin Number	Pin Name	Description	GPIO
1	ID	Communication line to the ID chip on an extension board	-
2	GND	Ground	GND
3	ADC(+)	Analog-to-Digital converter, alternatively positive part of differential ADC	PA05
4	ADC(-)	Analog-to-Digital converter, alternatively negative part of differential ADC	PA06
5	GPIO1	General Purpose I/O	PA12
6	GPIO2	General Purpose I/O	PA13
7	PWM(+)	Pulse-Width Modulation, alternatively positive part of differential PWM	PA01
8	PWM(-)	Pulse-Width Modulation, alternatively negative part of differential PWM	PA02
9	IRQ/GPIO	Interrupt request line and/or general purpose I/O	PD08
10	SS/GPIO	Client select for SPI and/or general purpose I/O	PD09
11	TWD	Data line for I ² C interface. Always implemented, bus type	PD01
12	TWCK	Clock line for I ² C interface. Always implemented, bus type	PD00
13	RXD	Receiver line of target device UART	PB16
14	TXD	Transmitter line of target device UART	PB15
15	SS	Client select for SPI, should preferably be unique	PA14
16	MOSI	Host out Client in line of Serial Peripheral Interface	PA16
17	MISO	Host in Client out line of Serial Peripheral Interface	PA15
18	SCK	Clock for Serial Peripheral Interface	PA17
19	GND	Ground	GND
20	VCC	Power for extension board	VCC_P3V3

3.7. Extension Power Header

The PIC32CM SG00/GC00 Curiosity Pro development board has an Extension Power Header which consist of a dual row, 4-pin, 100 mil pitch, right angle male header. It enables the user to supply the PIC32CM SG00/GC00 Curiosity Pro development board and/or supply the Xplained Pro expansion boards. Care must be taken not to exceed the total current limitation of the on-board regulator when using the 3.3V pin.

Figure 3-11. Extension Power Header

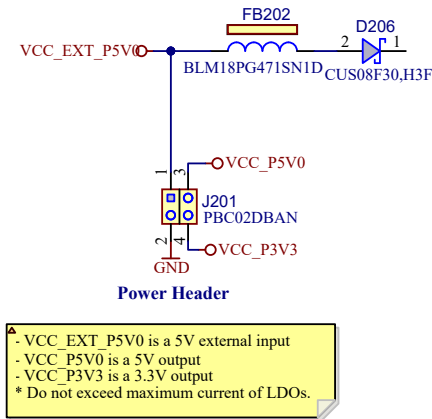

Table 3-5. Extension Power Header Pinout Definition

Pin Number	Pin Name	Net	Description
1	EXT_5V	VEXT_P5V0	External 5V input voltage
2	GND	GND	Ground
3	5V	VCC_P5V0	Unregulated 5V (output, derived from one of the input sources)
4	3.3V	VCC_P3V3	Regulated 3.3V voltage (output)

3.8. mikroBUS Socket

One mikroBUS socket, J500-J501, is available on the development board. This socket can be used to expand the functionality using the MikroElektronika Click boards™. The mikroBUS connector consists of two 1x8 female headers with SPI, I²C, UART, RST, PWM, analog, and interrupt lines as well as 3.3V, 5V, and GND power lines. For additional information on the interface and Click boards, refer to the MikroElektronika [webpage](#).

Note that some of these pins are shared with both Extension headers and Arduino UNO R3 headers.

Figure 3-12. mikroBUS Headers (J500 and J501) Schematic

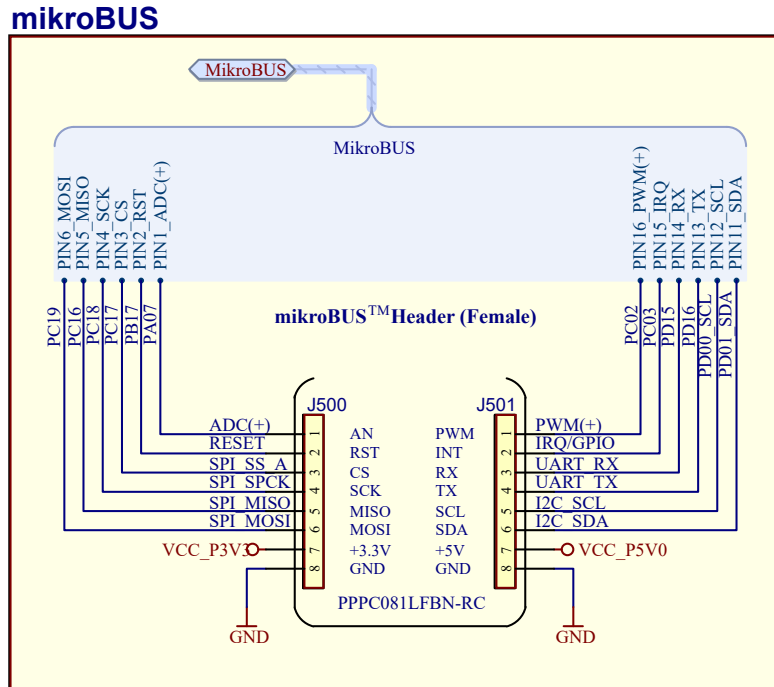

Table 3-6. mikroBUS Socket Pin Assignment

Pin Number	Pin Name	Description	GPIO
1	AN	Analog	PA07
2	RST	Reset	PB17
3	CS	SPI Chip Select	PC17
4	SCK	SPI Clock	PC18
5	MISO	SPI Host Input Client Output	PC16
6	MOSI	SPI Host Output Client Input	PC19
7	+3.3V	VCC-3.3V power	VCC_P3V3
8	GND	Reference Ground	GND
9	GND	Reference Ground	GND
10	+5V	VCC-5V power	VCC_P5V0
11	SDA	I ² C Data	PD01
12	SCL	I ² C Clock	PD00
13	TX	UART Transmit	PD16
14	RX	UART Receive	PD15
15	INT	Hardware Interrupt	PC03
16	PWM	PWM output	PC02

3.9. Arduino UNO R3 Interface

The PIC32CM SG00/GC00 Curiosity Pro development board has an Arduino UNO R3 compatible header which enables the use of Arduino shields. Peripherals, such as ADC, SPI, I²C, UART, and PWM of the PIC32CM SG00/GC00 MCU can be interfaced with the Arduino shields using the Arduino UNO R3 interface. For additional information on the interface, refer to the [Arduino UNO R3](#).

Note that some of these pins are shared between Extension headers and mikroBUS socket.

Figure 3-13. ArduinoUNO Compatible Headers Schematic

ARDUINO UNO COMPATIBLE HEADERS

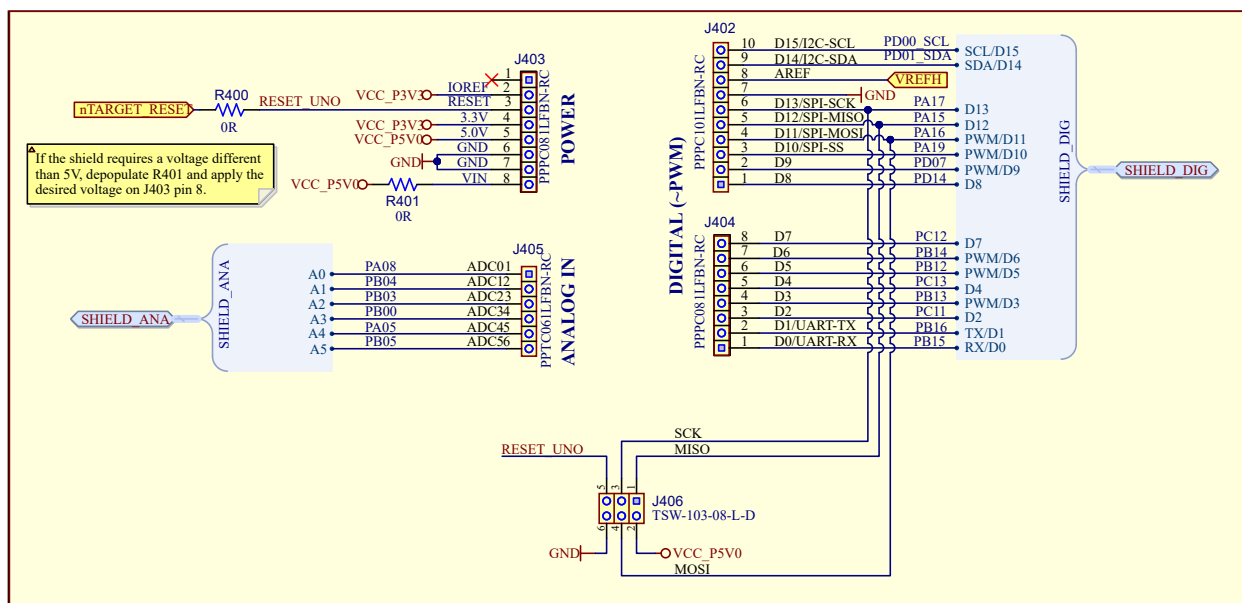

Table 3-7. Arduino UNO R3 (Analog In) Header Pin Assignment

Pin Number	Pin Name	Description	GPIO
1	ADC0	Analog input 0	PA08
2	ADC1	Analog input 1	PB04
3	ADC2	Analog input 2	PB03
4	ADC3	Analog input 3	PB00
5	ADC4	Analog input 4	PA05
6	ADC5	Analog input 5	PB05

Table 3-8. Arduino UNO R3 (Power) Header Pin Assignment

Pin Number	Pin Name	Description	GPIO
1	NC	Not connected	-
2	IOREF	Reference for digital logic V	VCC_P3V3
3	Reset	Reset	RESET
4	+3V3	+3V3 Power Rail	VCC_P3V3
5	+5V	+5V Power Rail	VCC_P5V0
6	GND	Ground	GND
7	GND	Ground	GND
8	VIN	Voltage Input	VCC_P5V0

Table 3-9. Arduino UNO R3 (Digital 1) Header Pin Assignment

Pin Number	Pin Name	Description	GPIO
1	D0/RX	Digital pin 0/GPIO	PB15
2	D1/TX	Digital pin 1/GPIO	PB16
3	D2	Digital pin 2/GPIO	PC11
4	D3/PWM	Digital pin 3/GPIO	PB13
5	D4	Digital pin 4/GPIO	PC13
6	D5/PWM	Digital pin 5/GPIO	PB12

Table 3-9. Arduino UNO R3 (Digital 1) Header Pin Assignment (continued)

Pin Number	Pin Name	Description	GPIO
7	D6/PWM	Digital pin 6/GPIO	PB14
8	D7	Digital pin 7/GPIO	PC12

Table 3-10. Arduino UNO R3 (Digital 2) Header Pin Assignment

Pin Number	Pin Name	Description	GPIO
1	D8	Digital pin 8/GPIO	PD14
2	D9/PWM	Digital pin 9/GPIO	PD07
3	D10/SS	SPI Chip Select	PA19
4	D11/MOSI	SPI1 Main Out Secondary In	PA16
5	D12/MISO	SPI Main In Secondary Out	PA15
6	D13/SCK	SPI serial clock output	PA17
7	GND	Ground	GND
8	AREF	Analog reference voltage	VREFH
9	D14/TWI_SDA	Digital pin /I ² C Data line	PD01
10	D15/TWI_SCL	Digital pin/I ² C Clock line	PD00

3.10. CAN Transceivers

The PIC32CM SG00/GC00 Curiosity Pro development board features the CAN protocol version 2.0 A/B which includes the CAN Flexible Data Rate Frame format (CAN-FD, ISO 11898-1:2015) by means of two CAN transceivers, ATA6561 on the J502 and J503 connectors. For additional information about the CAN transceivers, refer to the “ATA6561 Data Sheet” (*DS20005991*) available at [product webpage](#).

The schematic includes TVS diodes protection (D550 and D501) and switches (SW500 and SW501) if it is required to disconnect the impedance (62 ohms + 62 ohms).

Figure 3-14. CAN Transceivers Schematic

CAN Transceivers

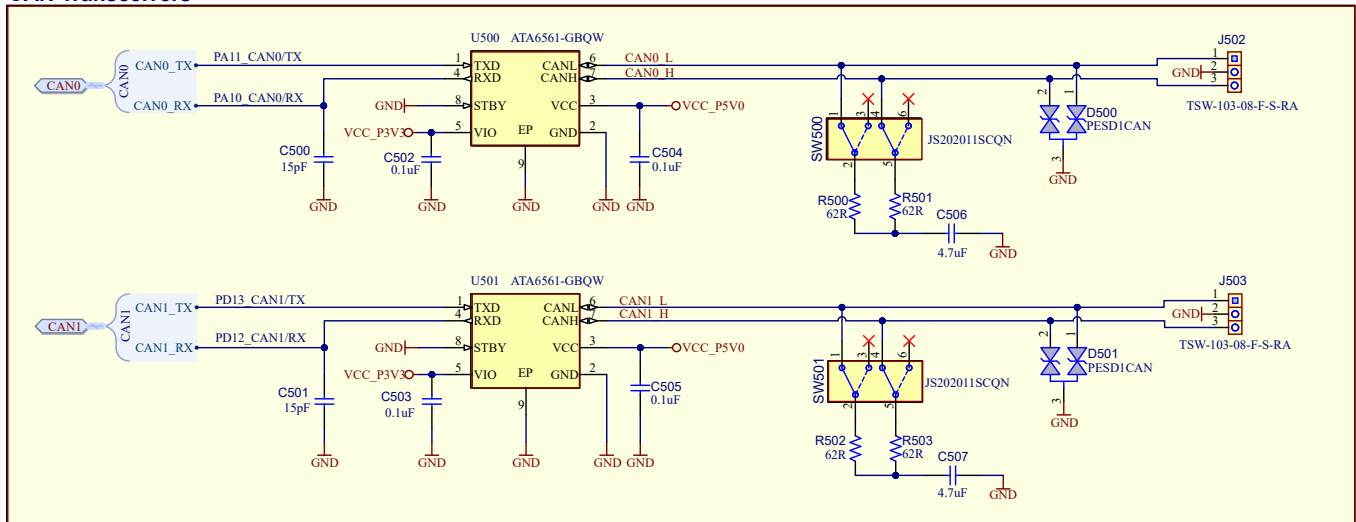

Table 3-11. CAN 0/1 Interfaces Pinout Definition

Pin Number	Pin Name	Description
1	CANL	CAN Low signal
2	GND	Ground
3	CANH	CAN High signal

3.11. Security IC

The PIC32CM SG00/GC00 Curiosity Pro development board provides TA101, a secure authentication IC for automotive and industrial security applications. Several package configuration options are available, but the selected one in the board is a SOIC-8 pinout with I²C interface.

The secure authentication IC is not populated in the board. For additional information about the authentication IC, refer to the “TA101 Data Sheet” (DS40002529) available at [product webpage](#).

Figure 3-15. TA101 IC Schematic

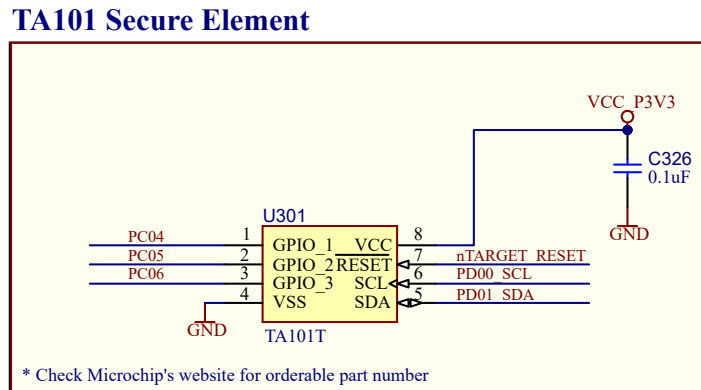

Table 3-12. TA101 Pin Configuration

Pin Number	Pin Name	Description	GPIO
1	GPIO_1	GPIO_1	PC04
2	GPIO_2	GPIO_2	PC05
3	GPIO_3	GPIO_3	PC06
4	VSS	Ground	GND
5	SDA	I ² C Data	PD01
6	SCL	I ² C Clock	PD00
7	/RESET	Reset Input, active low	nTARGET_RESET
8	VCC	2.7V-5.5V Power Supply	VCC_P3V3

3.12. 3.3V Voltage Reference

The development board features a high-precision buffered voltage reference for 3.3V, MCP1501T-33E/CHY, in an 6-Lead SOT-23 package supplied from 5V power input. This precision voltage is connected to the external voltage reference pin (ADC_VREFH) of the ADC module from the MCU. For additional information about the precision voltage reference, refer to the “MCP1501 Data Sheet” (DS20005474) available at [product webpage](#).

Figure 3-16. MCP1501T-33E/CHY Voltage Reference Schematic

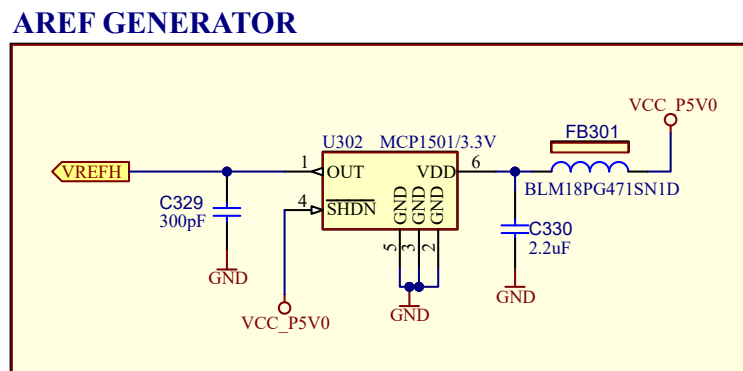

3.13. USB Interface

The development board has a Micro-USB Type-AB connector that features a Full-Speed USB 2.1 which supports USB Host and Device mode.

In case to use the USB as Host mode, to provide power to USB device, power the development board using the Extension Power Header by means of the VCC_EXT_P5V0 pin (pin 1 of J201) and pull down the PD11 GPIO (VBUS_EN) to enable the power switch MIC2005A, U200. Consider that the VBUS0 voltage suffers from the voltage dropout of the diodes, D200 and D206.

Figure 3-17. USB Schematic

USB0 - Host / Device

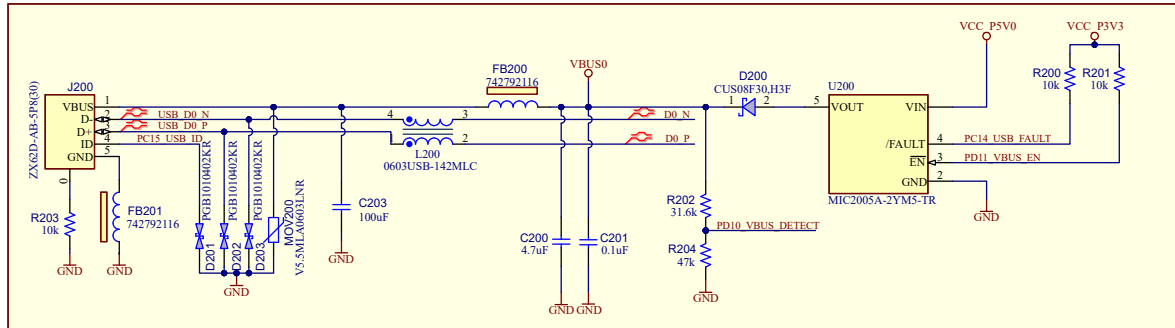

3.14. Buttons

The development board offers two user buttons, one touch button, and one reset button. The reset button allows reset the target without resetting the embedded debugger and without unplugging the power to the board.

The following figures show the function, description, and pins of each button used on the MCU.

Figure 3-18. User Buttons

USER BUTTON 0

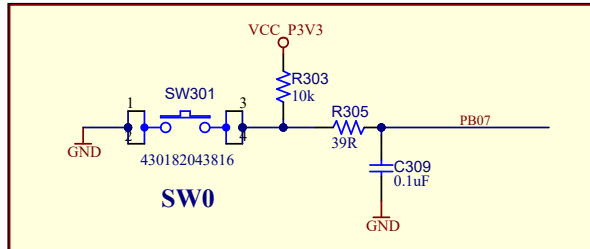

USER BUTTON 1

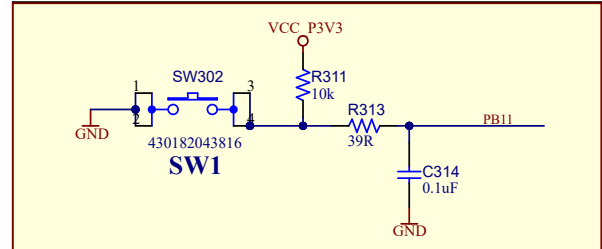

Figure 3-19. Touch Button

TOUCH BUTTON

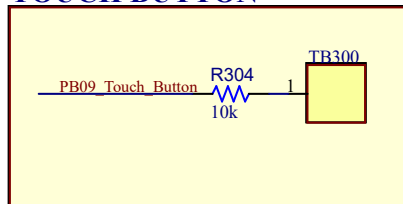
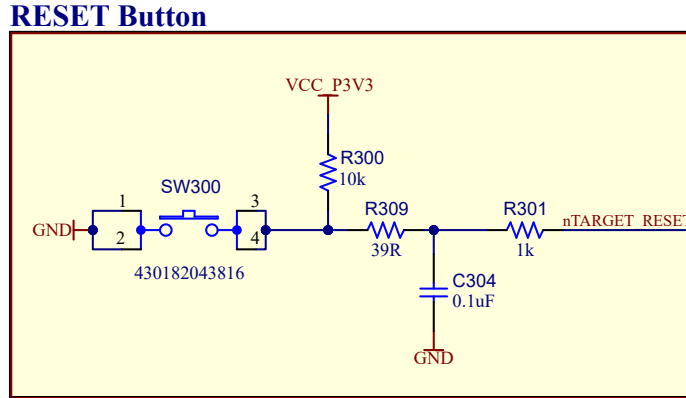

Figure 3-20. Reset Button



3.15. User LEDs

The development board offers two LEDs: D300 (green) and D301 (red). The following figure shows the function, description, and pins used on the MCU.

Figure 3-21. User LEDs

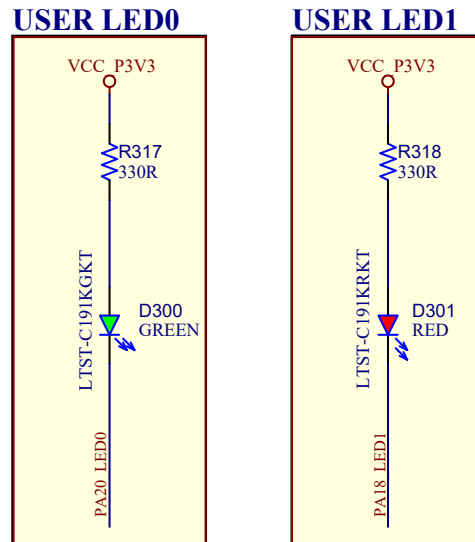

3.16. USERLDO Header

The PIC32CM SG00/GC00 microcontroller has one general purpose output pin, PD06 (USERLDO), generating 1.2V, 1.5V, 1.8V or 2.5V (VDDLDO) from VDDIO voltage and providing up to 100 mA. This USERLDO regulator can power an external component in the development board by means of a 2-pin header, J302.

Figure 3-22. USERLDO Header Schematic

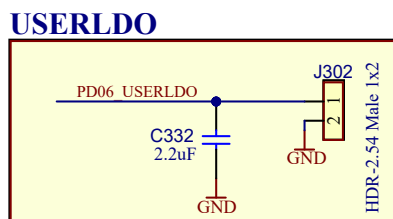

3.17. Tamper Detection

The PIC32CM SG00/GC00 microcontroller has a Real-Time Counter (RTC) that typically runs continuously to keep track of time. The RTC can wake up the device from sleep modes using the alarm or compare wake up, periodic wake up or overflow wake up mechanisms, or from the wake inputs.

The PIO PB08 is used as the RTC security tamper input pin (RTC/IN[5]), and the PIO PB10 is used as the RTC security tamper output pin (RTC/OUT[5]).

Figure 3-23. Tamper Detection Connector Schematic

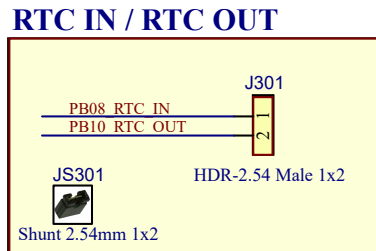

3.18. 10 kOhms Potentiometer

The development board includes a thumb wheel potentiometer of 10 kOhms connected to the PIO PB06 and referenced to 3.3V.

Figure 3-24. 10 kOhms Potentiometer Schematic

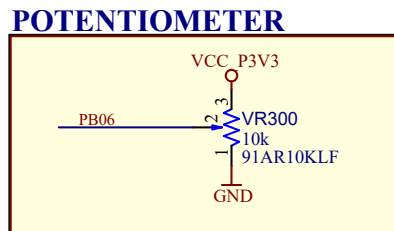

3.19. SWD Debug Connector

The development board can be programmed through a SWD protocol with an external tool. This tool is connected to the board through a 10-pin connector as shown in the following figure.

Figure 3-25. SWD Connector

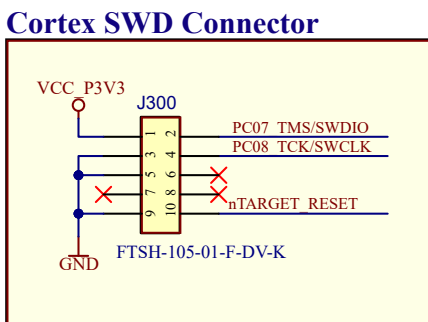

3.20. MPLAB PICKit On-Board 4

The MPLAB PICKit On-Board 4 (PKOB4) is a new generation In-Circuit Debugger. The MPLAB PKOB4 programs faster than its predecessor and is designed to use a high-speed 2.0 USB interface, which provides a feature rich debugging experience through one USB cable. The PKOB4 is intended to support programming, debugging, and a Data Gateway interface.

The MPLAB PKOB4 In-Circuit Debugger is compatible with these platforms:

- Microsoft Windows®7 or later
- Linux®
- macOS™

The MPLAB PKOB4 In-Circuit Debugger system provides the following advantages:

Features/Capabilities:

- Connects to computer through high-speed USB 2.0 (480 Mbits/s) cable
- Programs devices using MPLAB X IDE or MPLAB IPE
- Supports multiple hardware and software breakpoints, stopwatch, and source code file debugging
- Debugs the application in real time
- Sets break points based on internal events
- Monitors internal file registers
- Debugs at full speed
- Configures pin drivers
- Virtual COM support which can establish UART communication between the Host PC and the target device (PD19 and PD20 pins of the PIC32CM) using the following UART Configuration:
 - Baud rate: 115,200 bps
 - Only 8-bit character format
 - No hardware flow control
 - One stop-bit
- Field-upgradeable through an MPLAB X IDE firmware download
- Adds new device support and features by installing the latest version of MPLAB X IDE (available as a free download at www.microchip.com/mplabx/)
- Indicates debugger status through on-board LEDs

Performance/Speed:

- More and faster memory
- A Real-Time Operating System (RTOS)
- No firmware download delays incurred when switching devices
- A 32-bit MCU running at 300 MHz

3.20.1. Recovery Method

If the PKOB4 becomes unresponsive, follow these steps to recover the tool:

1. With the PIC32CM SG00/GC00 Curiosity Pro development board still powered, short the 2 pads (marked in the following figure) for approximately 10 seconds.

Figure 3-26. PKOB4 EBR Reset

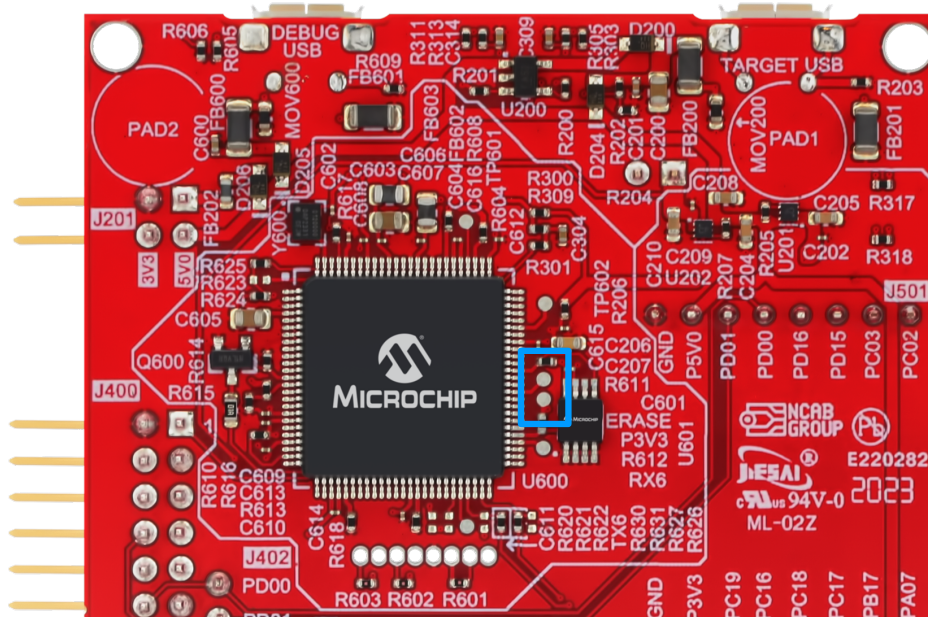

2. Open the latest version of MPLAB X IDE.
3. Click on the **Projects** tab and then select the project.
4. From the main menu, click **Debug**, the Debug Project properties page will be displayed.
5. Select **Hardware Tool Emergency Boot Firmware Recovery**.

Figure 3-27. MPLAB X IDE Interface

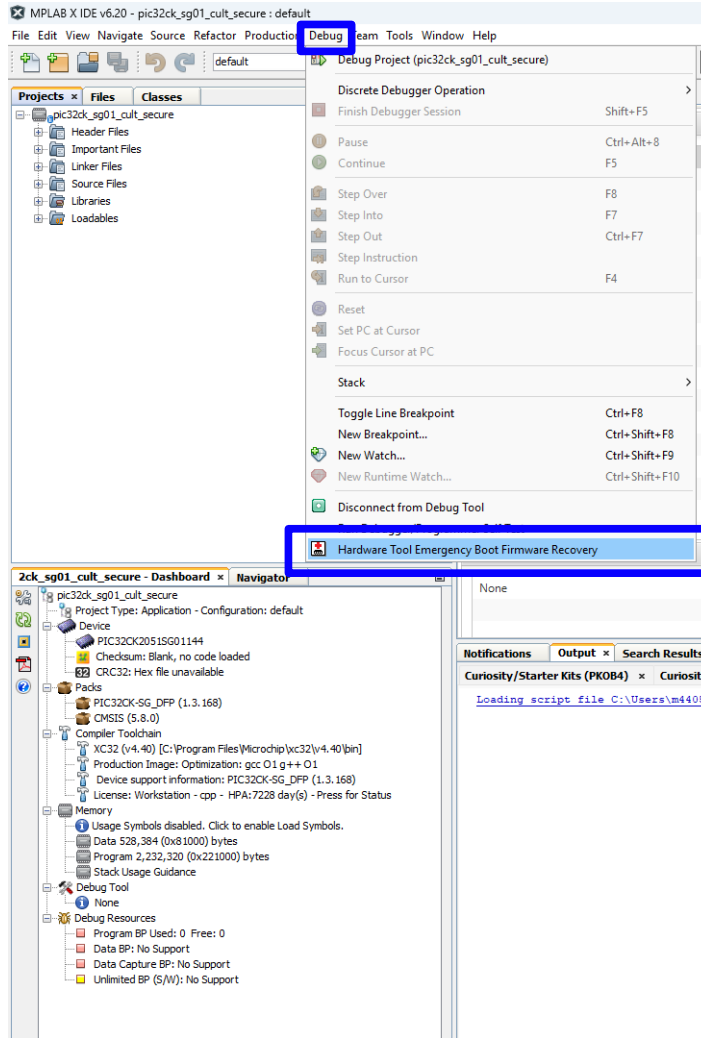

6. Follow the onscreen instructions to reset the tool to factory conditions.

For additional information on PKOB4, refer to the "MPLAB® PICkit4 User's Guide" (DS50002751), which is available for download at the following [location](#).

4. Hardware

The following sections provide the PIC32CM SG00/GC00 Curiosity Pro development board schematics and layout.

Note: The development board is intended for further engineering, development, demonstration, or evaluation purposes only and not for commercial use. Therefore, the development board is not fault tolerant and is not designed or manufactured with protective considerations, including but not limited to product safety measures typically found in finished commercial goods.

Note: This Curiosity Pro development board is designed to provide a demonstration platform for as many of the capabilities of the MCU as possible. Some of the signal multiplexing implemented to accomplish this end is not recommended for use in customer designs.

4.1. PIC32CM SG00/GC00 Curiosity Pro Schematics

This section contains the following schematics for the PIC32CM SG00/GC00 Curiosity Pro development board:

- Top Level, [Figure 4-1](#)
- Power, [Figure 4-2](#)
- Target MCU, [Figure 4-3](#)
- Extension and Arduino Headers, [Figure 4-4](#)
- CAN connector and mikroBUS socket, [Figure 4-5](#)
- PKOB4, [Figure 4-6](#)

Figure 4-1. Top Level Schematic

PIC32CM SG00 / GC00 Curiosity Pro

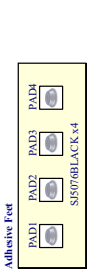
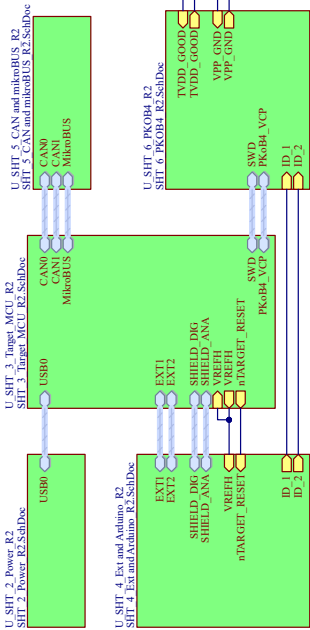

Mounting Holes

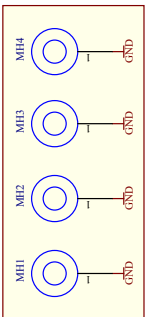

All resistors are 1% unless otherwise noted

CPM	Board Name	PCBA (SCH)	PCB	U300
EA36K74A	EA PIC32CM GC00 Curiosity Pro	02-01074	04-11983	PIC32CM61T23C00100-IFE-SX-SL3
EA51N28A	EA PIC32CM SG00 Curiosity Pro	02-01076	04-11983	PIC32CM61T23S00100-IFE-SX-SL3
EV17V75A	PIC32CM GC00 Curiosity Pro	02-06987	04-11983	PIC32CM61T23C00100-IFE-SX-SL3
EV53V42A	PIC32CM SG00 Curiosity Pro	02-06988	04-11983	PIC32CM61T23S00100-IFE-SX-SL3

Figure 4-2. Power Schematic

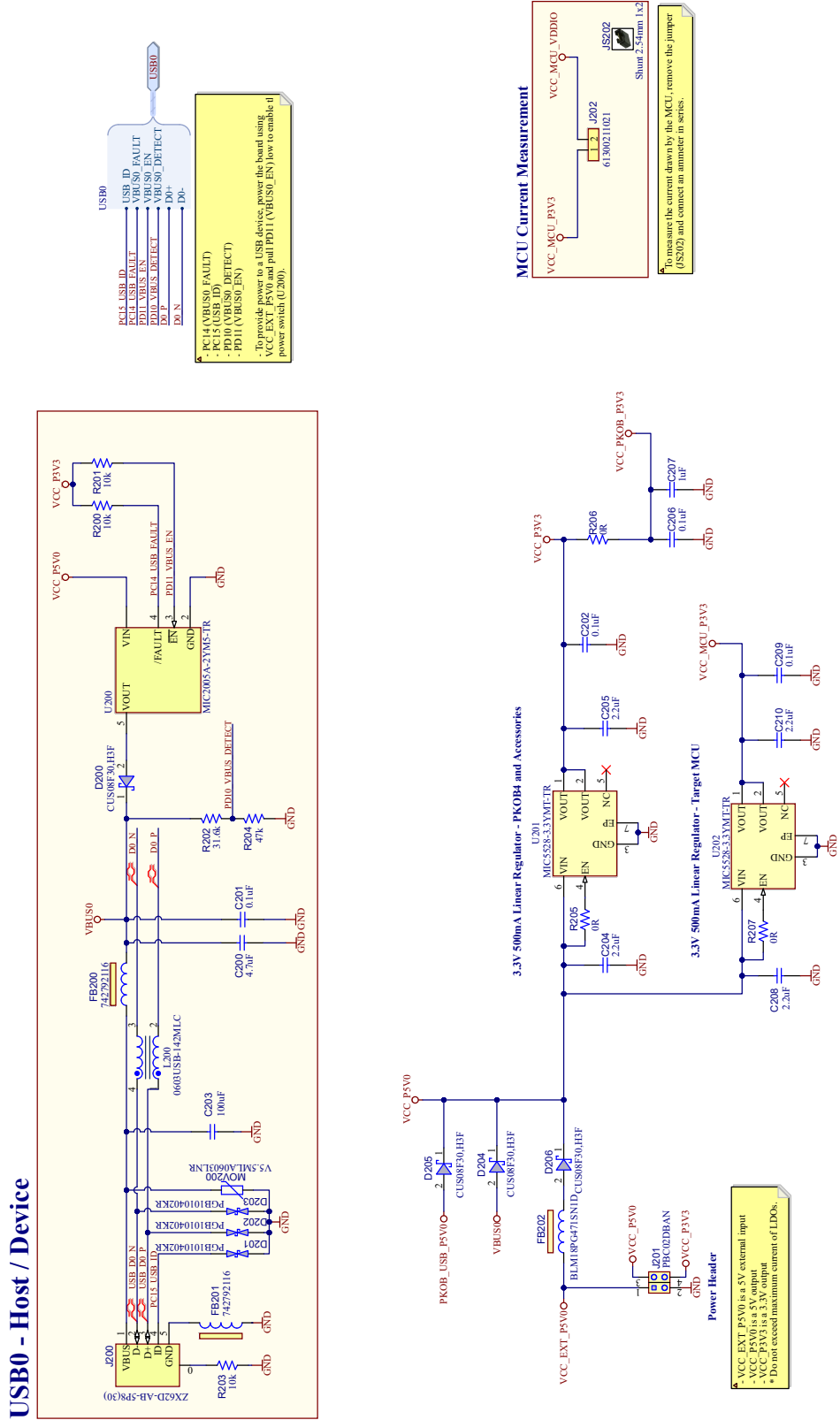

Figure 4-3. MCU Schematic

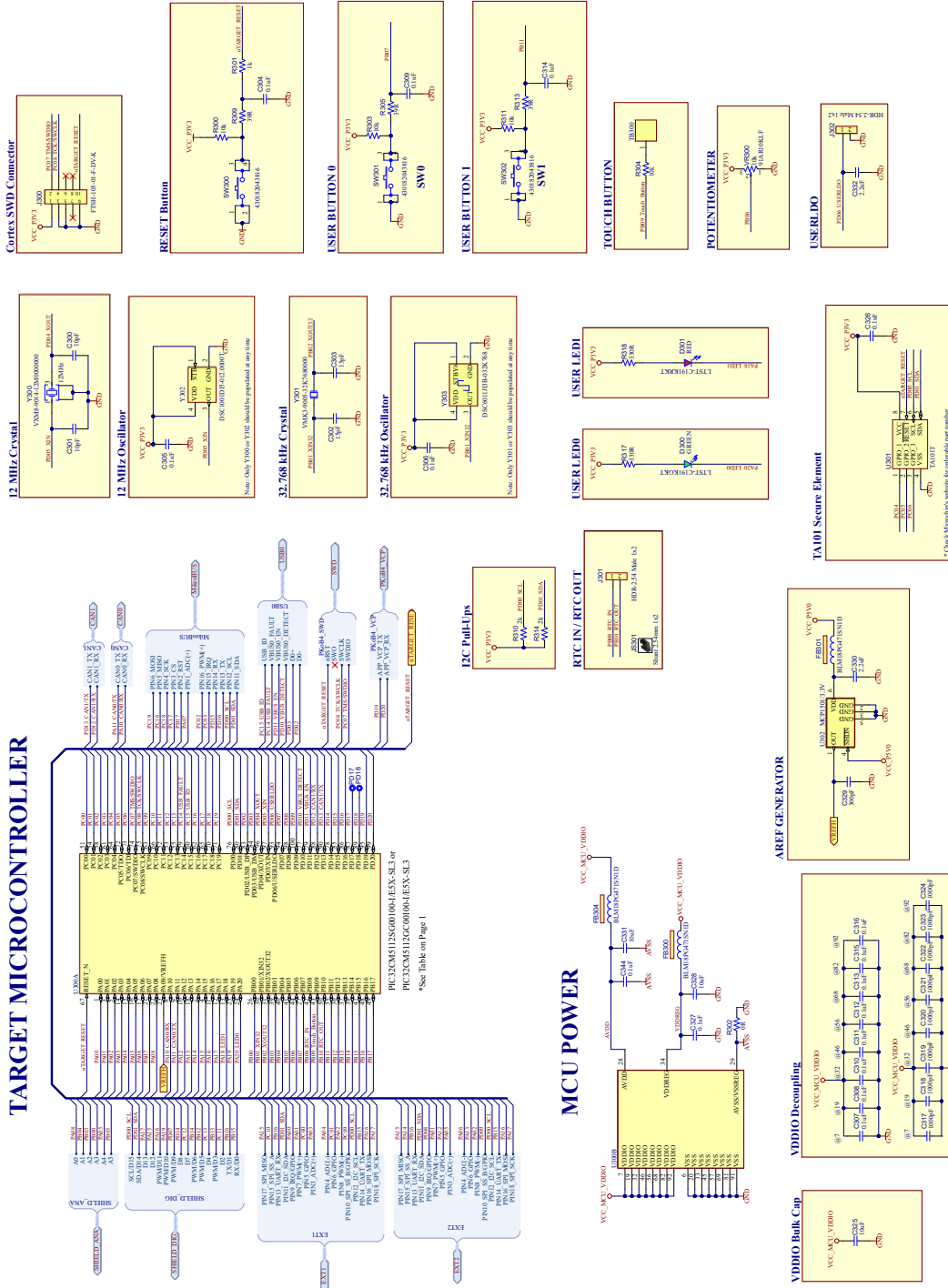
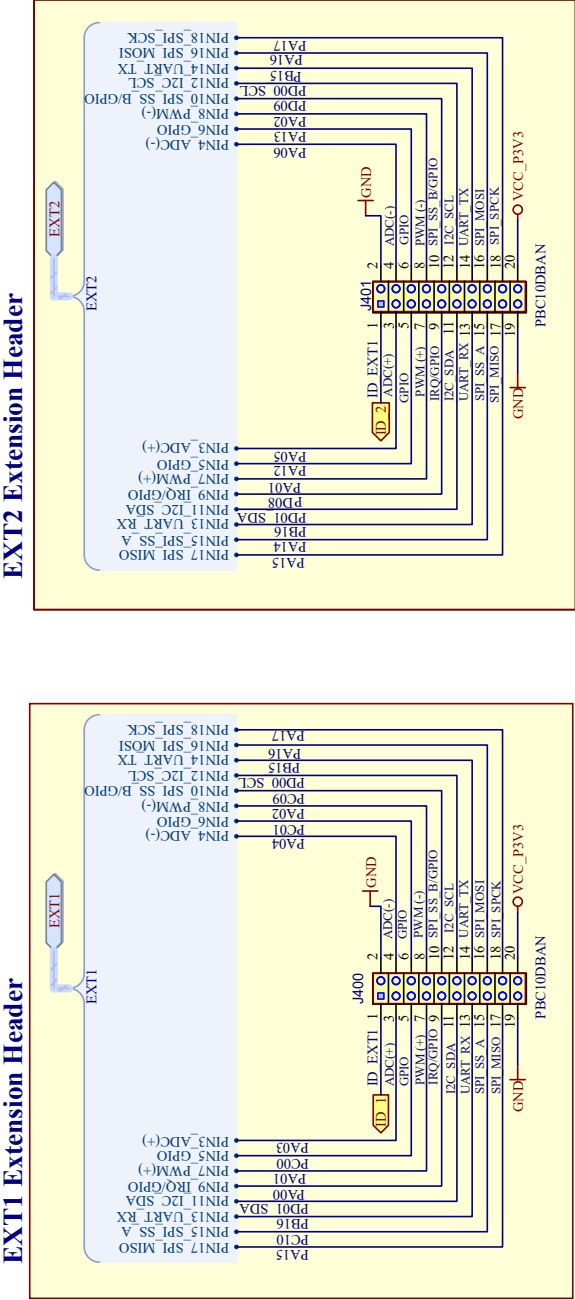

Figure 4-4. Extension and Arduino Headers Schematic



ARDUINO UNO COMPATIBLE HEADERS

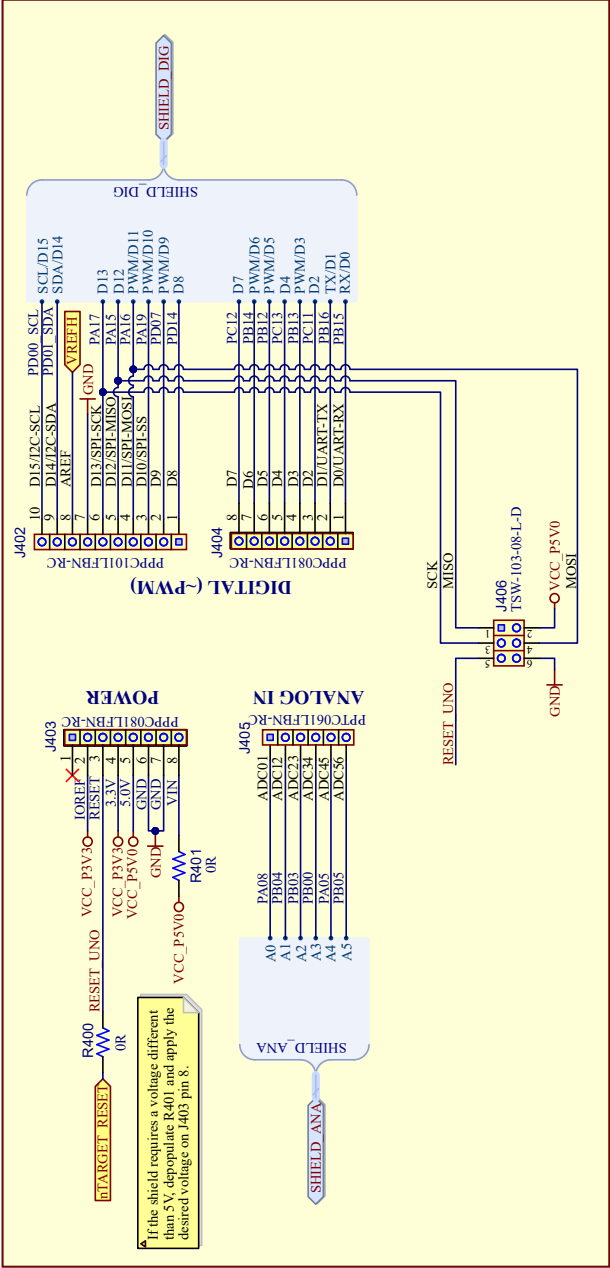
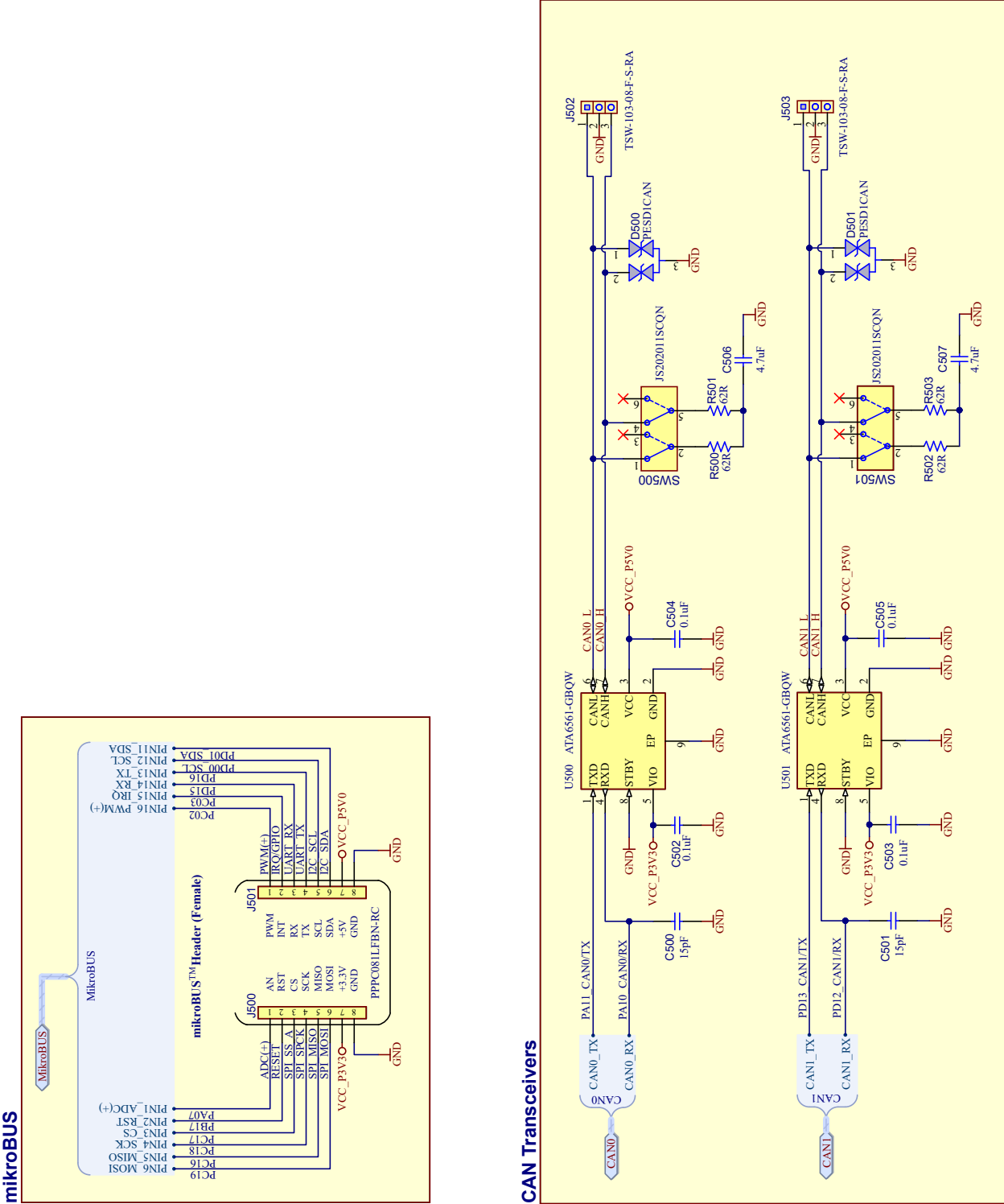

Figure 4-5. CAN Connector and mikroBUS Socket Schematic



4.2. PIC32CM SG00/GC00 Curiosity Pro Layout

This section contains the layout graphics for the PIC32CM SG00/GC00 Curiosity Pro development board:

- Layer 1: Top Layer, [Figure 4-7](#)
- Layer 2: Mid Layer 1, [Figure 4-8](#)
- Layer 3: Mid Layer 2, [Figure 4-9](#)
- Layer 4: Mid Layer 3, [Figure 4-10](#)
- Layer 5: Mid Layer 4, [Figure 4-11](#)
- Layer 6: Bottom Layer, [Figure 4-12](#)
- Top Components Placement, [Figure 4-13](#)
- Bottom Components Placement, [Figure 4-14](#)

Figure 4-7. Top Layer (signal)

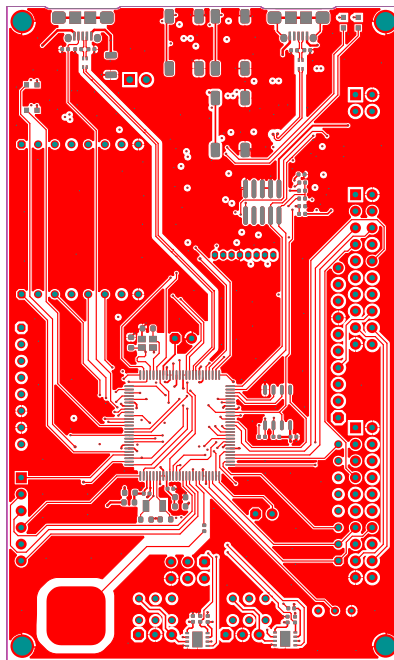

Figure 4-8. Mid Layer 1 (GND plane)

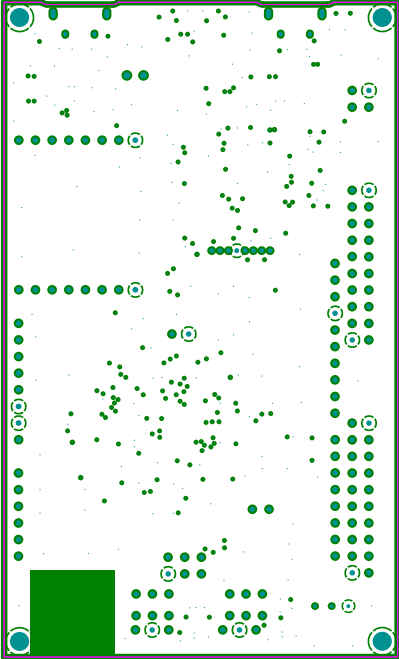

Figure 4-9. Mid Layer 2 (Power planes)

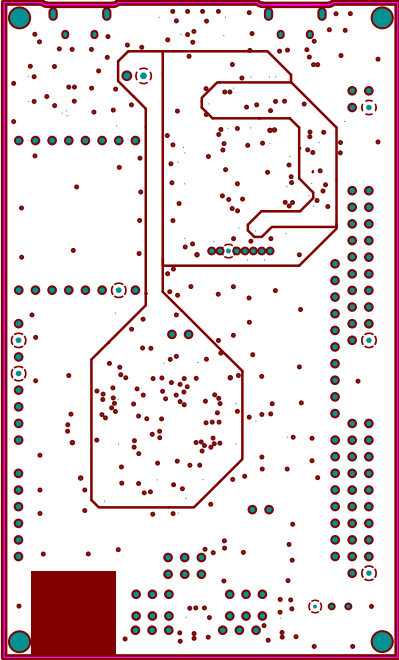

Figure 4-10. Mid Layer 3 (signal)

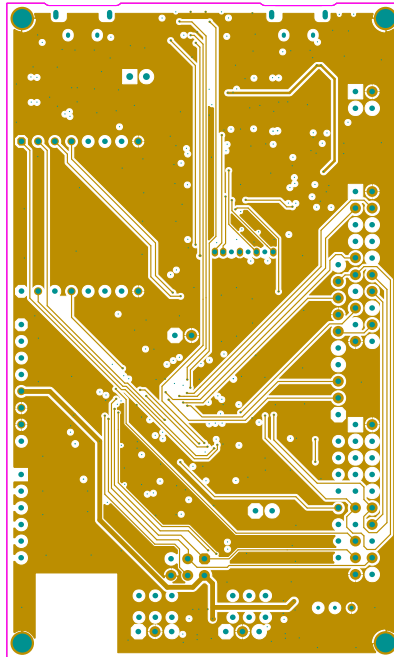

Figure 4-11. Mid Layer 4 (GND plane)

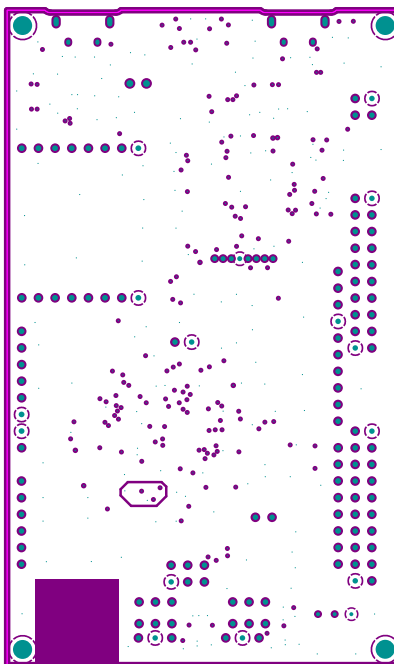

Figure 4-12. Bottom Layer (signal)

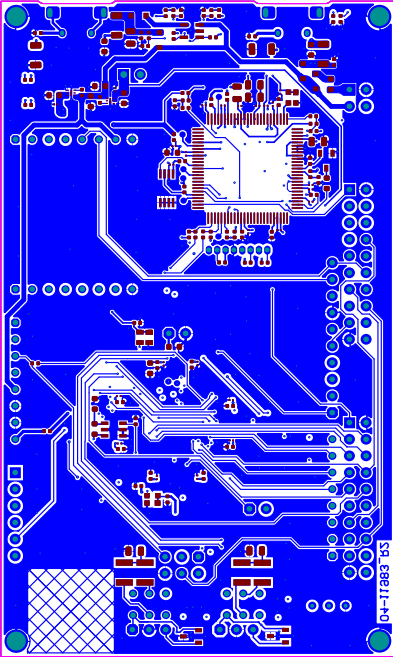

Figure 4-13. Top Components Placement

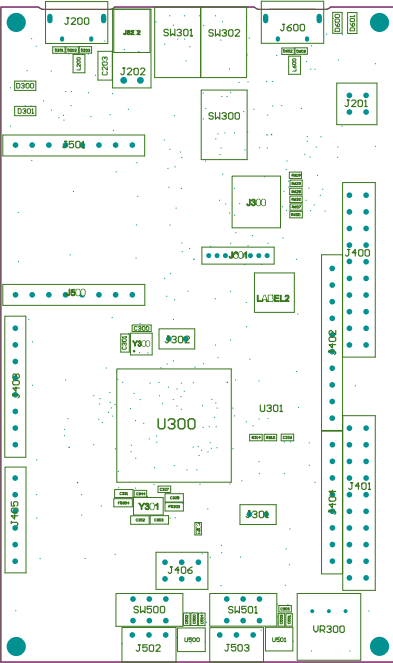
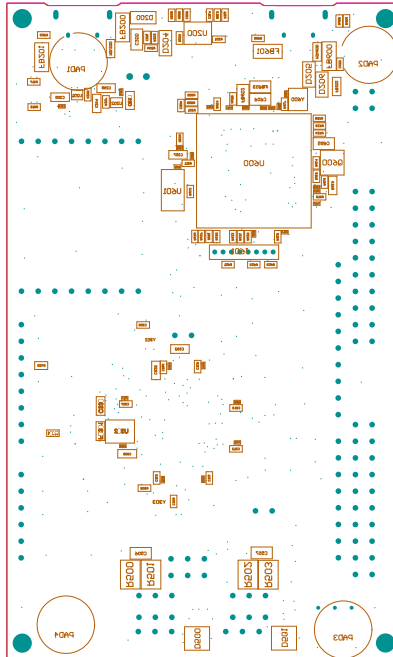

Figure 4-14. Bottom Components Placement



4.3. Bill of Materials

Table 4-1. PIC32CM SG00/GC00 Curiosity Pro Bill of Materials

Quantity	Designator	Description	Manufacturer 1	Manufacturer Part Number 1
5	C200, C506, C507, C605, C606	CAP CER 4.7 uF 25V 10% X7R SMD 0805	TDK Corporation	C2012X7R1E475K125AB
22	C201, C304, C305, C306, C307, C308, C309, C310, C311, C312, C313, C314, C315, C316, C326, C327, C344, C502, C503, C504, C505, C600	CAP CER 0.1 uF 50V 10% X7R SMD 0402	TDK Corporation	C1005X7R1H104K050BB
17	C202, C206, C209, C601, C602, C603, C604, C607, C608, C609, C610, C611, C612, C613, C614, C615, C616	CAP CER 0.1 uF 16V 10% X5R SMD 0201	Murata	GRM033R61C104KE84D
1	C203	CAP CER 100 uF 10V 20% X5R SMD 1206	TDK Corporation	C3216X5R1A107M160AC
6	C204, C205, C208, C210, C330, C332	CAP CER 2.2 uF 16V 10% X5R SMD 0603	TDK Corporation	C1608X5R1C225K080AB
2	C300, C301	CAP CER 10 pF 6.3V 1% C0G/NP0 SMD 0603	KYOCERA AVX	06036A100FAT2A
2	C302, C303	CAP CER 15 pF 10V 1% C0G/NP0 SMD 0603	Vishay	VJ0603A150FXQPW1BC
8	C317, C318, C319, C320, C321, C322, C323, C324	CAP 1000 pF 16V 10% X7R SMD 0201	Murata	GRM033R71C102KA01D
3	C325, C328, C331	CAP CER 10 uF 16V 20% X5R SMD 0603	Taiyo Yuden	EMK107BBJ106MA-T
1	C329	CAP CER 330 pF 25V 5% NPO SMD 0402	KEMET	C0402C301J3GAC7867
2	C500, C501	CAP CER 15 pF 5% 50V C0G/NP0 SMD 0402 AEC-Q200	Murata	GCM1555C1H150JA16D

Table 4-1. PIC32CM SG00/GC00 Curiosity Pro Bill of Materials (continued)

Quantity	Designator	Description	Manufacturer 1	Manufacturer Part Number 1
4	D200, D204, D205, D206	DIO SCKTY CUS08F30,H3F 30V 800 mA SOD-323	Toshiba Semiconductor and Storage	CUS08F30,H3F
5	D201, D202, D203, D602, D603	DIO TVS BIDIR PGB101 SMD 0402	Littelfuse Inc.	PGB1010402KR
2	D300, D600	DIO LED GREEN 2V 30 mA 35 mcd Clear SMD 0603	Lite-On Inc	LTST-C191KGKT
1	D301	DIO RED 2V 20 mA 54 mcd CLEAR SMD 0603	Lite-On	LTST-C191KRKT
2	D500, D501	TVS DIODE 24VWM 70VC SOT23	NXP Semiconductors	PESD1CAN,215
1	D601	DIO LED YELLOW 2.1V 20 mA 6mcd Clear SMD 0603	Lite-On	LTST-C190YKT
4	FB200, FB201, FB600, FB601	FERRITE 500R@100 MHz 2.5A SMD 1206	Würth Elektronik	742792116
4	FB202, FB300, FB301, FB304	FERRITE 470R@100 MHz 1A SMD 0603	Murata	BLM18PG471SN1D
2	FB602, FB603	FERRITE 2A 600R SMD 0805	TDK Corporation	MPZ2012S601AT000
2	J200, J600	CON USB2.0 Micro-AB Female ZX62D-AB-5P8(30) TOP MOUNT TH R/A	Hirose Connector	ZX62D-AB-5P8(30)
1	J201	CON HDR-2.54 Male 2x2 Gold 5.84MH TH R/A	Sullins Connector Solutions	PBC02DBAN
1	J202	CON HDR-2.54 Male 1X2 Gold 6mmMH TH R/A	Würth Elektronik	61300211021
1	J300	CON HDR-1.27 Male 2x5 Gold 3.05MH SMD VERT	Samtec	FTSH-105-01-F-DV-K
2	J301, J302	CON HDR-2.54 Male 1x2 Gold 5.84MH TH VERT	FCI	68000-202HLF
2	J400, J401	CON HDR-2.54 Male 2x10 Rotated 180 Degrees Gold TH RT ANGLE	Sullins Connector Solutions	PBC10DBAN
1	J402	CON HDR-2.54 Female 1x10 Gold TH VERT	Sullins Connector Solutions	PPPC101LFBN-RC
4	J403, J404, J500, J501	CON HDR-2.54 Female 1x8 Gold TH	Sullins Connector Solutions	PPPC081LFBN-RC
1	J405	CON HDR-2.54 Female 1x6 Tin TH VERT	Sullins Connector Solutions	PPTC061LFBN-RC
1	J406	CON HDR-2.54 Male 2x3 Gold 5.84MH TH VERT	Samtec	TSW-103-08-L-D
2	J502, J503	CON HDR-2.54 Male 1x3 Gold 5.84MH TH R/A	Samtec	TSW-103-08-F-S-RA
1	J601	CON HDR-1.27 Female 1x8 TH VERT	Sullins Connector Solutions	LPPB081NFFN-RC
2	L200, L600	INDUCTOR CHOKE COMMON MODE USB3.0 0.42K@1.9 GHz Ohm SMD L1.52W0.76H1.07	Coilcraft	0603USB-142MLC
1	LABEL2	LABEL PCBA 6x6mm Info Text	ACT Logimark AS	505462
2	MOV200, MOV600	RES VARISTOR 8.2V 30A V5.5MLA0603LNR SMD 0603	Littelfuse Inc.	V5.5MLA0603LNR
12	R200, R201, R203, R300, R303, R304, R311, R604, R608, R609, R626, R630	RES TKF 10k 1% 1/10W SMD 0402	Panasonic	ERJ-2RKF1002X
3	R202, R600, R615	RES TKF 31.6k 1% 1/10W SMD 0402	Panasonic	ERJ-2RKF3162X
3	R204, R607, R616	RES TKF 47k 5% 1/10W SMD 0402	Panasonic	ERJ-2GEJ473X

Table 4-1. PIC32CM SG00/GC00 Curiosity Pro Bill of Materials (continued)

Quantity	Designator	Description	Manufacturer 1	Manufacturer Part Number 1
7	R205, R206, R207, R302, R400, R401, R613	RES TKF 0R 1/16W SMD 0402	Yageo	RC0402JR-070RL
1	R301	RES TKF 1k 1% 1/10W SMD 0402	Panasonic	ERJ-2RKF1001X
3	R305, R309, R313	RES TKF 39R 1% 1/16W SMD 0402	Yageo	RC0402FR-0739RL
2	R310, R314	RES TKF 2k 1% 1/10W SMD 0402	Panasonic Electronic Components	ERJ-2RKF2001X
11	R317, R318, R605, R606, R622, R624, R625, R627, R629, R631, R632	RES TKF 330R 1% 1/16W SMD 0402	Yageo	RC0402FR-07330RL
4	R500, R501, R502, R503	RES TKF 62R 1% 1/2W SMD 1210 AEC-Q200	Panasonic	ERJ-14NF62R0U
3	R601, R602, R603	RES TKF 100k 1% 1/10W SMD 0402 AEC-Q200	Panasonic	ERJ-2RKF1003X
1	R610	RES TKF 100R 5% 1/10W SMD 0603	Vishay	CRCW0603100RJNEA
3	R611, R612, R614	RES TKF 4.7k 1% 1/16W SMD 0402	Yageo	RC0402FR-074K7L
1	R617	RES TKF 5.62k 1% 1/16W SMD 0402 AEC-Q200	Vishay	CRCW04025K62FKED
3	R618, R619, R620	RES TKF 3.3k 5% 1/10W SMD 0402	Panasonic - ECG	ERJ-2GEJ332X
3	R621, R623, R628	RES TKF 15k 1% 1/10W SMD 0402	Panasonic Electronic Components	ERJ-2RKF1502X
3	SW300, SW301, SW302	SWITCH TACT SPST 12V 50 mA PTS645SM43SMTR92 LFS SMD	C&K Components	PTS645SM43SMTR92 LFS
2	SW500, SW501	SWITCH SLIDE DPDT 6V 300MA JS202011CQN TH	C&K Components	JS202011CQN
1	VR300	RES TRIMMER Cermet 10k 20% 500 mW TH 91A	Bourns	3352T-1-103LF
Microchip Parts listed below				
1	Q600	MCHP ANALOG MOSFET N-CH TN2106 60V 280 mA 360 mW 2.5R SOT23-3	Microchip Technology	TN2106K1-G
1	U200	MCHP ANALOG POWER SWITCH 2.7V to 5.5V 0.5A ACTIVE LO MIC2005A-2YM5-TR SOT23-5	Microchip Technology	MIC2005A-2YM5-TR
2	U201, U202	MCHP ANALOG LDO 3.3V MIC5528-3.3YMT-TR 6-TDFN	Microchip Technology	MIC5528-3.3YMT-TR
1	U300	MCHP MCU 32-BIT 48 MHz 512 KB 128 KB PIC32CM5112GC00100-I/E5X-SL3 TQFP-100	Microchip Technology	PIC32CM5112GC00100-I/E5X-SL3
1	U302	MCHP ANALOG VREF 3.3V MCP1501T-33E/CHY SOT-23-6	Microchip Technology	MCP1501T-33E/CHY
2	U500, U501	MCHP INTERFACE CAN ATA6561-GBQW VDFN-8	Microchip Technology	ATA6561-GBQW
1	U600	MCHP MCU 32-BIT 300 MHz 2MB 384 KB ATSAME70N21B-ANT LQFP-100	Microchip Technology	ATSAME70N21B-ANT
1	U601	MCHP MEMORY SERIAL EEPROM 256k I2C 24LC256T-I/MS MSOP-8	Microchip Technology	24LC256T-I/MS
1	Y300	CRYSTAL 12 MHz 10 pF 150 Ohms SMD L2.5W2H0.55	Microchip Technology	VXM8-9014-12M0000000
1	Y301	MCHP CRYSTAL 32.768 kHz 12.5 pF VMK3-9005-32K7680000 SMD L3.2W1.5H0.9	Microchip Technology	VMK3-9005-32K7680000

Table 4-1. PIC32CM SG00/GC00 Curiosity Pro Bill of Materials (continued)

Quantity	Designator	Description	Manufacturer 1	Manufacturer Part Number 1
1	Y600	MCHP CLOCK OSCILLATOR SINGLE 12.00 MHz DSC6011J12B-012.0000 SMD VLGA	Microchip Technology	DSC6011J12B-012.0000
Mechanical Parts to be added in the package				
2	JS202, JS301	MECH HW JUMPER 2.54mm 1x2 GOLD	Sullins Connector Solutions	QPC02SXGN-RC
1	LABEL1	LABEL PCBA 18x6mm Datamatrix Assy# / Rev / Serial / Date	ACT Logimark AS	505462
4	PAD1, PAD2, PAD3, PAD4	MECH HW RUBBER PAD Cylindrical flat top D8H2.8 Black	3M	SJ5076BLACK x4, SJ5076BLACK
PCB				
1	PCB1	Printed Circuit Board		04-11983-R2
Do Not Populate Parts listed below				
0	U301	MCHP INTERFACE SECURITY I2C TA101T-Y250C2X01-00T-VAO SOIC-8	Microchip Technology	TA101T-Y250C2X01-00T- VAO
0	Y302	MCHP CLOCK OSCILLATOR SINGLE 12 MHz DSC1001DI5-012.0000 SMD-2520	Microchip Technology	DSC1001DI5-012.0000T
0	Y303	MCHP CLOCK OSCILLATOR SINGLE 32.768 kHz DSC6011J13B-032K768 VLGA-4	Microchip Technology	DSC6011J13B-032K768

5. Revision History

Revision B - 04/2025

The following updates were performed for this revision:

- Part numbers were updated to include EV53V42A/EV17V75A in the following sections:
 - [Introduction](#)
 - [Kit Contents](#)
- Added an Important note to [PIC32CM SG00/GC00 Microcontroller](#)

Revision A - 09/2024

This is the initial release of the document.

Microchip Information

Trademarks

The “Microchip” name and logo, the “M” logo, and other names, logos, and brands are registered and unregistered trademarks of Microchip Technology Incorporated or its affiliates and/or subsidiaries in the United States and/or other countries (“Microchip Trademarks”). Information regarding Microchip Trademarks can be found at <https://www.microchip.com/en-us/about/legal-information/microchip-trademarks>.

ISBN: 979-8-3371-1034-9

Legal Notice

This publication and the information herein may be used only with Microchip products, including to design, test, and integrate Microchip products with your application. Use of this information in any other manner violates these terms. Information regarding device applications is provided only for your convenience and may be superseded by updates. It is your responsibility to ensure that your application meets with your specifications. Contact your local Microchip sales office for additional support or, obtain additional support at www.microchip.com/en-us/support/design-help/client-support-services.

THIS INFORMATION IS PROVIDED BY MICROCHIP “AS IS”. MICROCHIP MAKES NO REPRESENTATIONS OR WARRANTIES OF ANY KIND WHETHER EXPRESS OR IMPLIED, WRITTEN OR ORAL, STATUTORY OR OTHERWISE, RELATED TO THE INFORMATION INCLUDING BUT NOT LIMITED TO ANY IMPLIED WARRANTIES OF NON-INFRINGEMENT, MERCHANTABILITY, AND FITNESS FOR A PARTICULAR PURPOSE, OR WARRANTIES RELATED TO ITS CONDITION, QUALITY, OR PERFORMANCE.

IN NO EVENT WILL MICROCHIP BE LIABLE FOR ANY INDIRECT, SPECIAL, PUNITIVE, INCIDENTAL, OR CONSEQUENTIAL LOSS, DAMAGE, COST, OR EXPENSE OF ANY KIND WHATSOEVER RELATED TO THE INFORMATION OR ITS USE, HOWEVER CAUSED, EVEN IF MICROCHIP HAS BEEN ADVISED OF THE POSSIBILITY OR THE DAMAGES ARE FORESEEABLE. TO THE FULLEST EXTENT ALLOWED BY LAW, MICROCHIP’S TOTAL LIABILITY ON ALL CLAIMS IN ANY WAY RELATED TO THE INFORMATION OR ITS USE WILL NOT EXCEED THE AMOUNT OF FEES, IF ANY, THAT YOU HAVE PAID DIRECTLY TO MICROCHIP FOR THE INFORMATION.

Use of Microchip devices in life support and/or safety applications is entirely at the buyer’s risk, and the buyer agrees to defend, indemnify and hold harmless Microchip from any and all damages, claims, suits, or expenses resulting from such use. No licenses are conveyed, implicitly or otherwise, under any Microchip intellectual property rights unless otherwise stated.

Microchip Devices Code Protection Feature

Note the following details of the code protection feature on Microchip products:

- Microchip products meet the specifications contained in their particular Microchip Data Sheet.
- Microchip believes that its family of products is secure when used in the intended manner, within operating specifications, and under normal conditions.
- Microchip values and aggressively protects its intellectual property rights. Attempts to breach the code protection features of Microchip products are strictly prohibited and may violate the Digital Millennium Copyright Act.
- Neither Microchip nor any other semiconductor manufacturer can guarantee the security of its code. Code protection does not mean that we are guaranteeing the product is “unbreakable”. Code protection is constantly evolving. Microchip is committed to continuously improving the code protection features of our products.