

## 3D dToF all-in-one lidar module



Product status link

[VL53L9CX](#)

### Features

- Fast and accurate 3D direct Time-of-Flight (dToF) camera module
  - Multizone ranging output with up to 54 x 42 separate zones and binning options
  - On-chip processing streaming 2D IR image, depth and ambient maps
  - Confidence level and reflectance maps generated in postprocessing
  - Ranging from <5 cm up to 9 m
  - Up to 100 Hz frame rate capability
  - On-chip histogram processing and algorithmic compensation minimize or remove the impact of cover glass crosstalk and veiling glare
- Fully integrated miniature module with wide field of view (FoV)
  - Scan by two vertical-cavity surface-emitting lasers (VCSEL) flood illumination
    - 940 nm invisible light and integrated analog driver
  - 71° diagonal FoV using metasurface optical elements (MOE) on both transmitter and receiver
  - Receiving array of single photon avalanche diodes (SPADs)
  - Size: 12.8 x 6.1 x 4.6 mm
- Easy integration
  - True all-in-one module with integrated SPAD sensor and VCSEL PMIC
  - Single reflowable component
  - Flexible power supply options:
    - Supports dual power supply operation: 1.2 V & 3.3 V
  - Compatible with a wide range of cover glass materials

### Applications

- Robotics
  - SLAM
  - Obstacle avoidance
  - Small object identification
- Augmented reality/virtual reality (AR/VR) enhancement.
  - Dual camera stereoscopy assistance thanks to 2D and depth multizone distance measurement at 60 fps
  - 3D room mapping (multizone and multiobject detection)
  - Gesture recognition and skeletal tracking
- Industrial applications
  - Content management thanks to wide FoV and multizone scanning (liquid level control, load in trucks, tanks, waste bins)
  - People mapping
- Smart homes
  - Smart buildings and smart lighting (user detection to wake up devices)
- IoT
  - User and object detection

- Mobile devices
  - Telephoto zoom camera assist. High resolution and long range allow image crop to align with telephoto camera.
  - Laser-assisted autofocus (LAF). Enhances the camera AF system speed and robustness, especially in difficult low-light or low-contrast scenes.
  - Video focus tracking. 60 Hz ranging allows optimization of continuous focus algorithm.
- Projectors
  - Keystone correction for video projectors

## Description

The VL53L9CX is STMicroelectronics' dToF 3D lidar all-in-one module, offering a high spatial resolution of 2.3 K zones. It features a 71° diagonal FoV, with 1° angular resolution across a 55° x 42° FoV. It also delivers accurate ranging from below 5 cm to 9 m.

The combination of long distance ranging and high resolution makes it ideal for applications such as people counting, content monitoring, gesture recognition, smart building, and more.

The VL53L9CX can stream full-resolution processed data at up to 100 Hz, making it one of the fastest, truly integrated dToF 3D lidar modules on the market. A dual-scan flood illumination strategy replaces traditional sequential dot scanning, enabling robust detection of small objects and edges while eliminating motion artifacts in fast-moving scenes. These two unique features make the device particularly suitable for SLAM, obstacle avoidance, and small object detection in robotics and drones.

The VL53L9CX consumes only 150 mW of typical system power and comes in a compact package that measures 12.8 mm x 6.1 mm x 4.6 mm. This device offers a cost-effective solution for many applications, which include AR/VR and battery-powered IoT devices. For outdoor use, it delivers excellent ranging performance even under strong ambient light and is compatible with various cover glass materials.

The VL53L9CX is completely calibration-free and a true "all-in-one" mini-lidar. It integrates a SPAD array, postprocessing SoC, two VCSELs, physical infrared filters, metasurface optical elements (MOE), and an embedded power management IC. Its reflowable design further simplifies integration into diverse systems, reducing both complexity and cost and enabling rapid deployment.

Available output data includes: depth, 2D IR (with and without active illumination), reflectance, and confidence. Depth data are output directly via MIPI or I3C interfaces, ensuring broad compatibility with a wide range of CPU architectures.

The two VCSELs of the VL53L9CX emit fully invisible 940 nm IR light. Certified as Class 1 laser-safe, the device incorporates multilevel laser-safety checks that ensure eye safety and reliable operation.

# 1 Application schematic

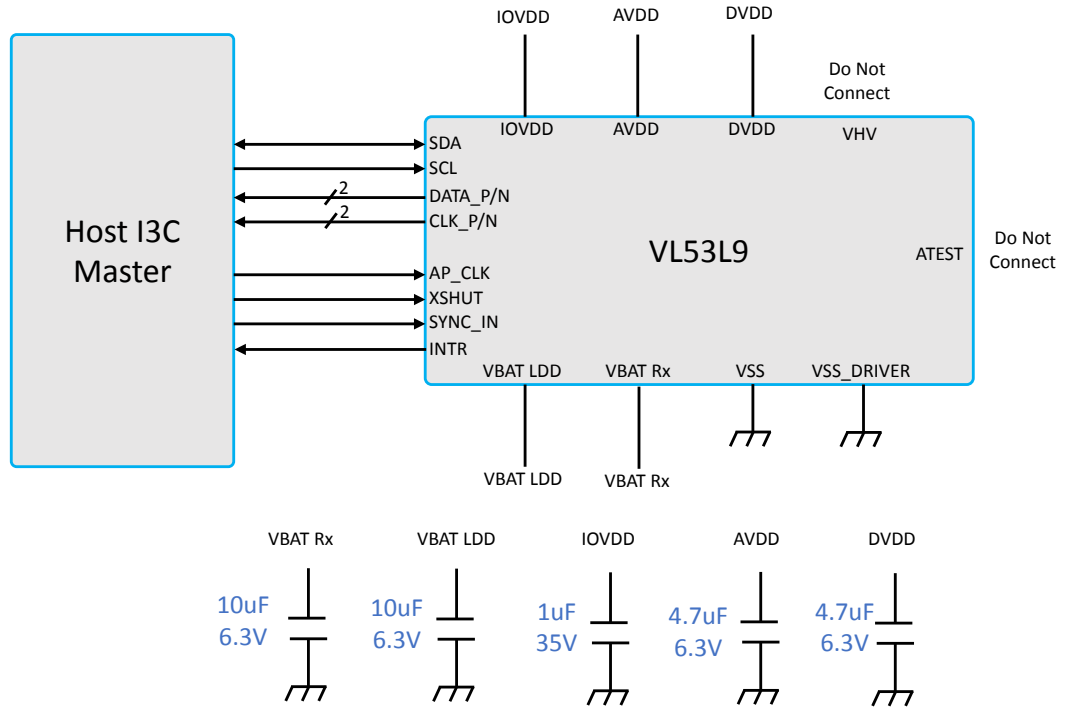
**Figure 1. Example application schematic**

**Table 1. Power supply details**

Voltage rail	Range
VBAT	2.8 V to 4.8 V
AVDD	2.8 V or 3.3 V
DVDD	1.2 V
IOVDD	1.2 V or 1.8V

## Revision history

**Table 2. Document revision history**

Date	Version	Changes
25-Feb-2025	1	Initial release
03-Oct-2025	2	Updated <i>Features</i> and <i>Description</i> to indicate that ranging is possible up to 9 m.
24-Feb-2026	3	Updated cover image. <i>Features</i> : Updated to indicate that ranging is possible up to 9 m. Changed "60 Hz frame rate capability" with "100 Hz frame rate capability". Updated <i>Description</i> .

**IMPORTANT NOTICE – READ CAREFULLY**

STMicroelectronics NV and its subsidiaries (“ST”) reserve the right to make changes, corrections, enhancements, modifications, and improvements to ST products and/or to this document at any time without notice.

In the event of any conflict between the provisions of this document and the provisions of any contractual arrangement in force between the purchasers and ST, the provisions of such contractual arrangement shall prevail.

The purchasers should obtain the latest relevant information on ST products before placing orders. ST products are sold pursuant to ST’s terms and conditions of sale in place at the time of order acknowledgment.

The purchasers are solely responsible for the choice, selection, and use of ST products and ST assumes no liability for application assistance or the design of the purchasers’ products.

No license, express or implied, to any intellectual property right is granted by ST herein.

Resale of ST products with provisions different from the information set forth herein shall void any warranty granted by ST for such product.

If the purchasers identify an ST product that meets their functional and performance requirements but that is not designated for the purchasers’ market segment, the purchasers shall contact ST for more information.

ST and the ST logo are trademarks of ST. For additional information about ST trademarks, refer to [www.st.com/trademarks](http://www.st.com/trademarks). All other product or service names are the property of their respective owners.

Information in this document supersedes and replaces information previously supplied in any prior versions of this document.

© 2026 STMicroelectronics – All rights reserved